

NEW

With Organic EL Display

Digital Fiber Sensor

FX-250 SERIES

| CE |

“Ease of use” evolves to the next generation.



Overwhelmingly easy to understand, Organic EL display

The clear, high-visibility flat panel ensures easy operation to reduce setting time and minimize setting errors. It contributes to improved efficiency on the production site.

Character display

The "Readable" setting screen offers improved ease of use.

Large output indicator

The ON / OFF status can be recognized at a glance even from a distance.



Conventional model



NEW FX-250 series

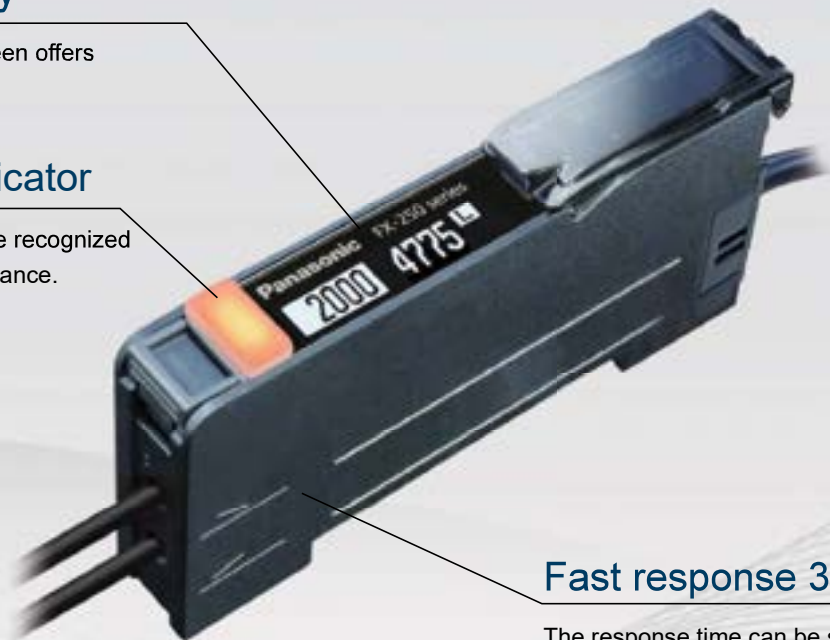

Fast response 35 μ s

The response time can be selected from five patterns to enable flexible use in a wide range of applications.

Enables intuitive operation without referring to the manual

Reduces setting time

Minimizes setting errors

7-segment display

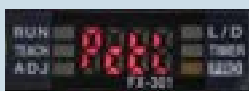
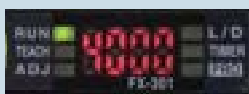

NEW FX-250 series

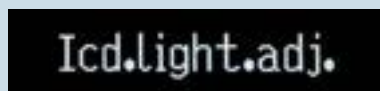
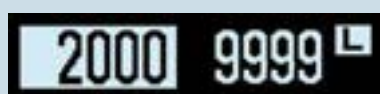

Improved digital display area

Sufficient incident light intensity is ensured even when a small-diameter fiber is used, thus contributing to stable sensing.

Dual display

The display shows threshold value and incident light intensity simultaneously.

Clear character display for at-a-glance understanding

Information is displayed in the language even first-time users can understand.

Compact body

The compact body can be easily mounted to small equipment and robotic hands with limited installation spaces.

Main unit size

W 10.0 × H 32.0 × D67.5 mm W 0.394 × H 1.260 × D 2.657 in

NEW
FX-250 series

NEW
FX-250 series

Conventional model

Conventional model



Space required for opening and closing the cover

The small cover requires a minimum space for opening and closing, thus enabling space-saving installation.

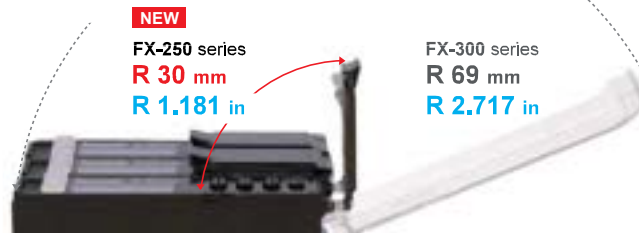

New function

Smart limit teaching Simultaneous execution of teaching and circumvention of saturation

* Only when limit teaching is used

Teaching is executed only with two pushes of a button, and this also achieves circumvention of saturation simultaneously. There is no need for separate adjustment of the light emission amount, thus contributing to reduction of setting man-hours.

Before

In the event the emitted light was too strong and caused incident light saturation, the light emitting amount had to be adjusted before teaching is performed.

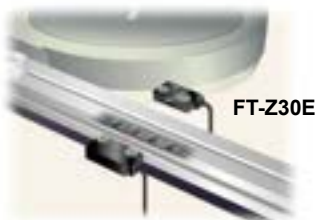
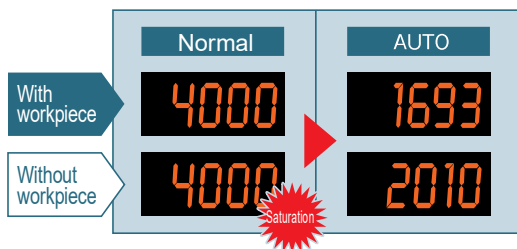

After

When limit teaching is executed under incident light saturation, circumvention of light saturation and setting of the threshold value is performed simultaneously. This adds extra convenience when using the thru-beam type to detect a very small object or transparent item.



* Only when limit teaching is used

Recommended to use as an amplifier of FD-F71 as well for liquid leak detection in semiconductor manufacturing machine.



* FD-F71 receives the beam when there is no liquid present.

Incident light intensity adjustable in 100 increments

The incident light intensity can be varied in 100 steps to allow flexible and precise adjustment of incident light intensity even when the incident light becomes saturated due to installation in a close distance or during detection of a transparent or very small workpiece, thus realizing stable detection.

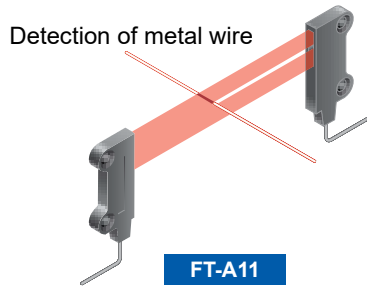

Detection of transparent sticker on transparent sheet

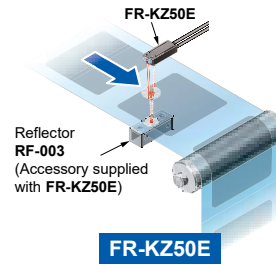

Alternate frequency interference prevention function

In the case the fibers are arranged side by side, mutual interference can be prevented by setting different light emission frequencies (4 settings).

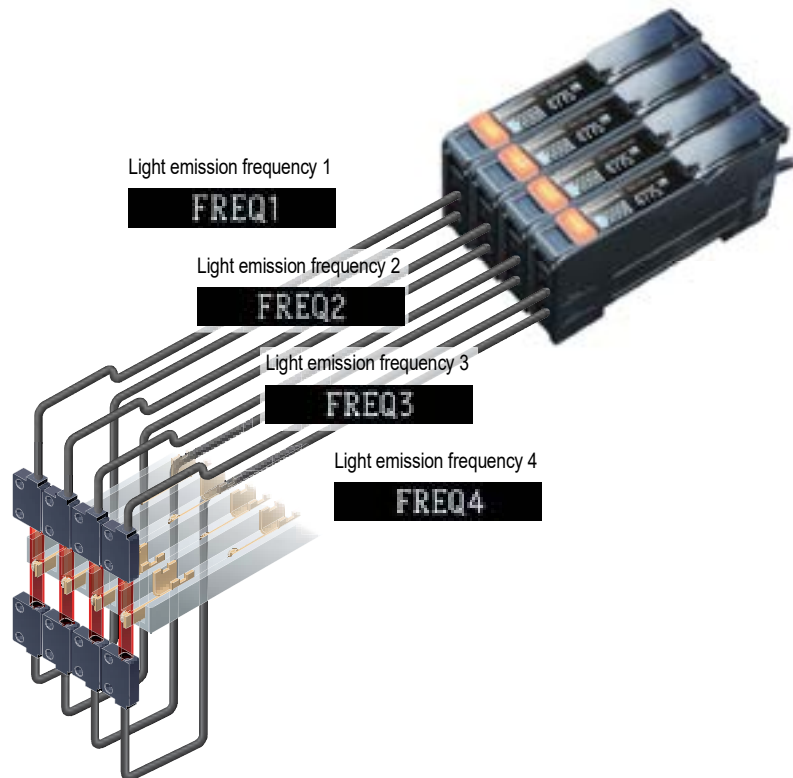

* Response time varies depending on light emission frequencies.

* When the alternate frequency interference prevention function is used, up to four fiber head units can be mounted in contact with each other.

Zero-set function

When a reflective type fiber is used, offsetting the incident light intensity to "0" with no workpiece present enables confirmation of only the change caused by the detected object.

When multiple amplifiers are mounted side by side, all displayed values can be set to "0."



Example 1: Using the zero-set function when displayed incident light intensity is "900"

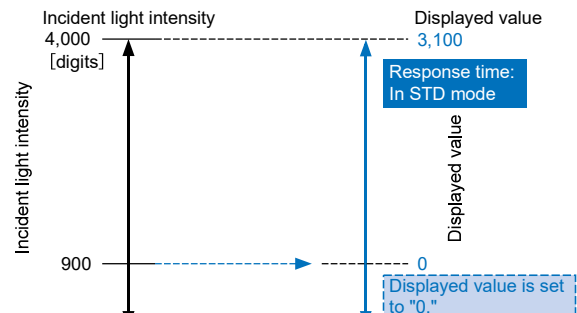

Equipped with three types of timer function

A variety of timer control operations can be carried out only by fiber sensors.

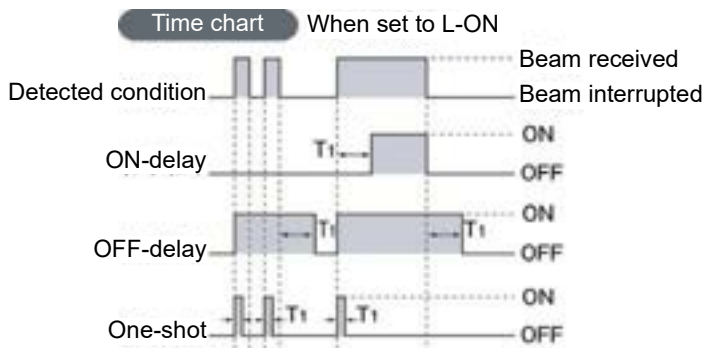

Timer period setting range: 1 to 9,999 ms, in 1-ms increments
(default setting: 1 ms)

Display and indicator can be set to OFF.

Since the digital display and large output indicator can stay turned off during use, the **FX-250** series is suitable for use with equipment that can be affected by light or heat.

Eco OFF (default setting)

The digital display dims when the unit is not operated for about 20 seconds.



Eco ON

The digital display dims when the unit is not operated for about 20 seconds. The digital display turns off when the unit is not operated for about 2 minutes.



Eco FULL

The digital display dims when the unit is not operated for about 20 seconds. The digital display and output indicator turn off when the unit is not operated for about 2 minutes.



Stable detection over long periods and short periods Stabilization of light emission amount

The built-in APC circuit stabilizes the short-time fluctuation of the light emission amount at the time of power on and the four-element light emitting diode ensures stable emission over long periods.

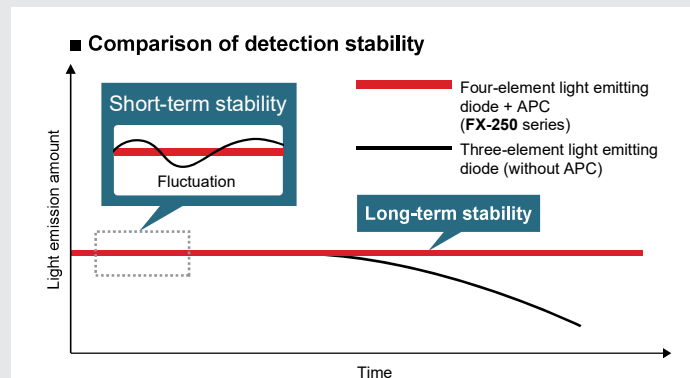
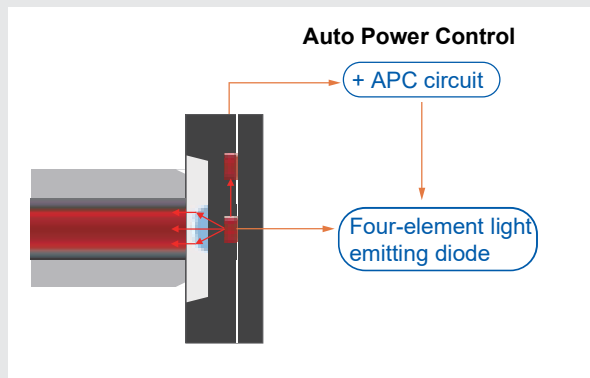

■ APC circuit

When power is turned on or when the temperature changes, the sensor's light emission amount fluctuates and causes instability of output. To solve this problem, the APC circuit controls the light emission amount to ensure short-term emission stability.

■ Four-element light emitting diode

When a conventional LED operates for a long period of time, the LED becomes damaged due to heat or the light intensity decreases due to oxidation. The four-element light emitting diode suppresses degradation of the light emitting element to the maximum extent and ensures long-term emission stability.

ORDER GUIDE

Amplifier

Appearance	Model No.	Emitting element	Output
	FX-251-C2	Red LED	NPN open-collector transistor
	FX-251P-C2		PNP open-collector transistor

End plates End plates are not supplied with the amplifier. Please order them separately when the amplifiers are mounted in cascade.

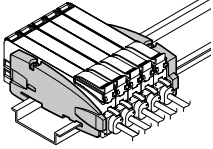
Appearance	Model No.	Description
	MS-DIN-E	<p>When an amplifier moves depending on the way it is installed on a DIN rail, these end plates clamp amplifiers into place on both sides. Make sure to use end plates when connecting multiple amplifiers together.</p> <p>Two pcs. per set</p>

OPTIONS

Designation	Model No.	Description
Amplifier mounting bracket	MS-DIN-2	Mounting bracket for amplifier

Amplifier mounting bracket

· **MS-DIN-2**

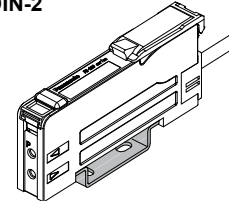

SPECIFICATIONS

Item	Type	NPN output type	PNP output type
	Model No.	FX-251-C2	FX-251P-C2
Applicable regulations	CE Marking (EMC Directive, RoHS Directive)		
Supply voltage	12 to 24 V DC $\pm 10\%$ Ripple P-P 10% or less		
Power consumption	960 mW or less (current consumption 40 mA or less at 24 V supply voltage)		
Output	NPN open-collector transistor		PNP open-collector transistor
	<ul style="list-style-type: none"> • Maximum sink current: 100 mA • Applied voltage: 30 V DC or less (between output and 0 V) • Residual voltage: 2 V or less (at maximum sink current) 		<ul style="list-style-type: none"> • Maximum source current: 100 mA • Applied voltage: 30 V DC or less (between output and +V) • Residual voltage: 2 V or less (at maximum source current)
	Output operation	Switchable either Light-ON or Dark-ON	
	Short-circuit protection	Incorporated	
Response time	H-SPD: 35 μ s or less, FAST: 60 μ s or less, STD: 250 μ s or less, LONG: 2 ms or less, H-PWR: 24 ms or less, selectable		
Output indicator	Orange LED turns on when output is ON.		
Sensitivity setting	2-point teaching / Limit teaching / Full-auto teaching / Manual adjustment		
Threshold value adjustment function	Incorporated		
Incident light intensity adjustment function	Incorporated, max. 100 steps		
Incident light intensity display range	H-SPD / FAST / STD: 0 to 4,000, LONG / H-PWR: 0 to 9,999		
Digital display	White organic EL display		
Various settings	Shift amount setting (percentage, fixed value), display style setting, display inversion setting, ECO setting, zero-set function		
Timer function	OFF-delay timer / ON-delay timer / One-shot timer, switchable either effective or ineffective (setting range: 1 to 9,999 ms in 1-ms increments)		
Interference prevention function	Incorporated (4 selectable frequencies) (Note 2)		
Environmental resistance	Protection	IP40 (IEC)	
	Ambient temperature	-10 to +55 °C +14 to +131 °F (If 4 to 7 units close mounting: -10 to +50 °C +14 to +122 °F or if 8 to 16 units close mounting: -10 to +45 °C +14 to +113 °F) (No dew condensation or icing allowed), Storage: -20 to +70 °C -4 to +158 °F	
	Ambient humidity	35 to 85% RH, Storage: 35 to 85% RH	
	Ambient illuminance	Incandescent light: 10,000 lx or less at the light-receiving face	
	Voltage withstandability	1,000 V AC for one min. between all supply terminals connected together and enclosure (Note 3)	
	Insulation resistance	20 M Ω or more, with 250 V DC megger between all supply terminals connected together and enclosure (Note 3)	
	Vibration resistance	10 to 150 Hz frequency, 0.75 mm 0.030 in double amplitude (100 m/s ² max.) in X, Y and Z directions for two hours each (without power supply)	
	Shock resistance	98 m/s ² acceleration (10 G approx.) in X, Y and Z directions five times each (without power supply)	
Emitting element (modulation type)	Red LED (Peak emission wavelength: 660 nm 0.026 mil)		
Material	Enclosure, cover, switch: Polycarbonate		
Cable	0.2 mm ² 3-core cabtyre cable, 2 m 6.562 ft long		
Cable extension	Extension up to total 100 m 328.084 ft is possible with 0.3 mm ² , or more, cable. (however, supply voltage 24 V DC or more)		
Weight	Net weight: 55 g approx., Gross weight: 80 g approx.		

- Notes: 1) Where measurement conditions have not been specified precisely, the conditions used were an ambient temperature of +23 °C **+73.4 °F**.
2) When the interference prevention function is used, set different light emission frequencies in the amplifiers for interference prevention.
3) The indicated voltage withstandability and insulation resistance values apply to the amplifier unit.

I/O CIRCUIT AND WIRING DIAGRAMS

FX-251-C2

I/O circuit diagram

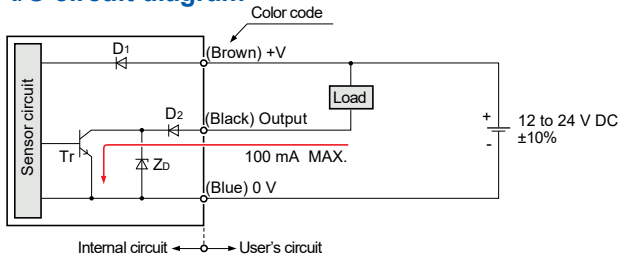

Wiring diagram

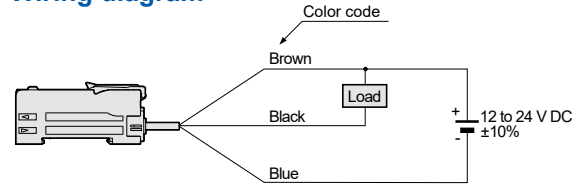

Symbols...
 D₁: Reverse supply polarity protection diode
 D₂: Reverse output polarity protection diode
 Z₀: Surge absorption zener diode
 T_r: NPN output transistor

FX-251P-C2

I/O circuit diagram

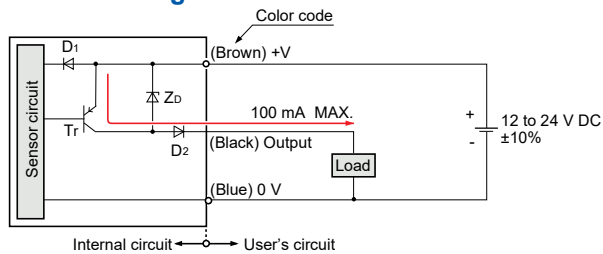

Wiring diagram

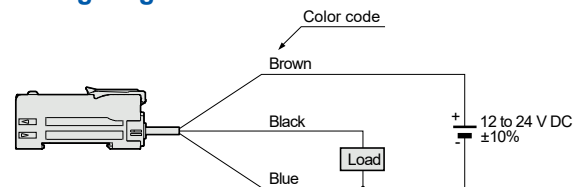

Symbols...
 D₁: Reverse supply polarity protection diode
 D₂: Reverse output polarity protection diode
 Z₀: Surge absorption zener diode
 T_r: PNP output transistor

PRECAUTIONS FOR PROPER USE

Refer to the instruction manual for details.

The instruction manual data can be downloaded from our website.

- This catalog is a guide to select a suitable product. Be sure to read instruction manual of the product prior to its use.



- Never use this product as a sensing device for personnel protection.
- In case of using sensing devices for personnel protection, use products which meet laws and standards, such as OSHA, ANSI or IEC etc., for personnel protection applicable in each region or country.

Wiring

- Make sure that the power supply is OFF while adding or removing the amplifiers.
- Note that if a voltage exceeding the rated range is applied, or if an AC power supply is directly connected, the product may get burnt or damaged.
- Note that short-circuit of the load or wrong wiring may burn or damage the product.
- Do not run the wires together with high-voltage lines or power lines, or put them in the same raceway. This can cause malfunction due to induction.
- Verify that the supply voltage variation is within the rating.
- If power is supplied from a commercial switching regulator, ensure that the frame ground (F.G.) terminal of the power supply is connected to an actual ground.
- In case noise generating equipment (switching regulator, inverter motor, etc.) is used in the vicinity of this product, connect the frame ground (F.G.) terminal of the

Others

- This product has been developed / produced for industrial use only.
- The specification may not be satisfied in a strong magnetic field.
- Do not use during the initial transient time (the following time) after the power supply is switched ON.
 H-SPD, FAST, STD: 0.5 sec., LONG, H-PWR: 1 sec.
- These sensors are only for indoor use.
- Avoid dust, dirt, and steam.
- Make sure that the product does not come in contact with oil, grease, organic solvents such as thinner, etc., strong acid or alkaline.
- This product cannot be used in an environment containing inflammable or explosive gases.
- Never disassemble or modify this product.
- This product adopts EEPROM. Settings cannot be done a million times or more because of the EEPROM's lifetime.
- The power input must meet the following requirements:
 1. Be certified for its region of use
 2. Have an output hold time of at least 20 ms
 3. Have a rated output voltage of 12 to 24 V DC $\pm 10\%$ ripple P-P 10% or less and a current capacity of 0.5 A or more
 4. If CE marking compliance is required, have SELV (Safety Extra Low Voltage)/PELV (Protective Extra Low Voltage) in accordance with the EMC Directive

DIMENSIONS (Unit: mm in)

For the external dimensions of the fibers and fiber options, refer to our website.
The CAD data can be downloaded from our website.

FX-251-C2 FX-251P-C2

Amplifier

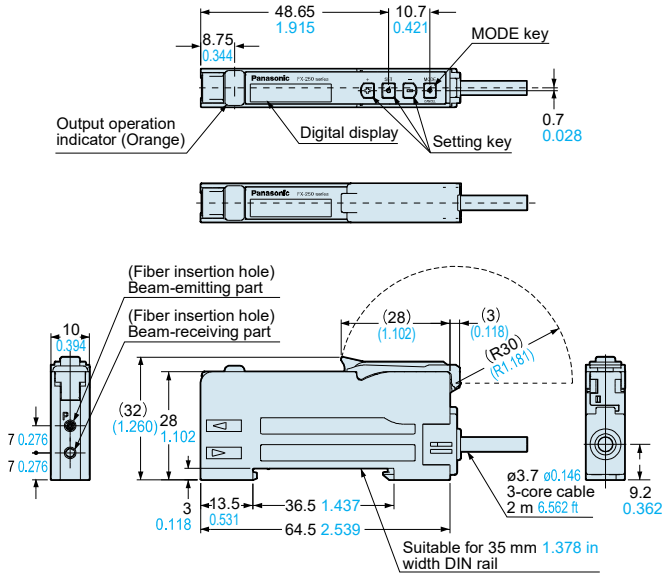

MS-DIN-2

Amplifier mounting bracket (Optional)

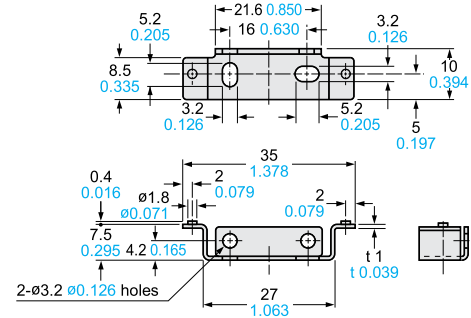

Material: Cold rolled carbon steel (SPCC)
(Uni-chrome plated)

MS-DIN-E

End plate (Optional)

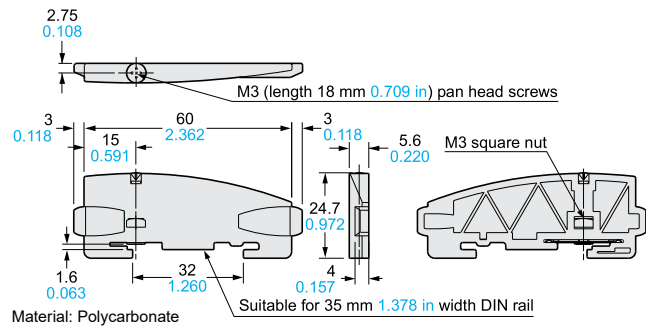





Material: Polycarbonate

Tough : Refer to a fiber which possesses both unbreakable (bending radius: R10 mm **R0.394 in**, reciprocating bending: 180°) and more flexible (bending radius: R4 mm **R0.157 in** or less) features.
Bending durability : Refer to a fiber which possesses unbreakable bending-resistant feature (bending radius: R10 mm **R0.394 in**, reciprocating bending: 180°).

LIST OF FIBERS

Super quality type

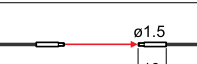
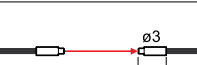
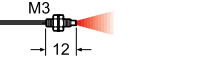
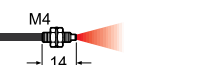
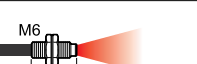
*Thru-beam type sensors are available as two pieces per set.

Type	Shape of fiber head (mm)	Model No.	Bending radius (mm)	Fiber cable length	Sensing range (mm in) (Note 2)		Beam axis dia. (mm)	Beam axis position / Inclination of beam axis	Optical transmission loss	Protection	Ambient temp.	
					FX-250 series	Other modes LONG FAST H-SPD						
Thru-beam	Threaded	 M3	Tough <small>Bending durability</small> FT-30	R2	2 m (Note 3)	STD 400 15.748 H-PWR 1,350 53.150	650 25.591 210 8.268 75 2.953	∅0.5	150 μm / ±2°	±10 %	IP67	-55 to +80 °C
		 M4	Tough <small>Bending durability</small> FT-40	R4		STD 1,200 47.244 H-PWR 3,600 141.732	1,700 66.929 530 20.866 190 7.480	∅1				
	Cylindrical	 ø1.5	Tough <small>Bending durability</small> FT-S20	R2		STD 400 15.748 H-PWR 1,350 53.150	650 25.591 210 8.268 75 2.953	∅0.5				
		 ø3	Tough <small>Bending durability</small> FT-S30	R4		STD 1,200 47.244 H-PWR 3,600 141.732	1,700 66.929 530 20.866 190 7.480	∅1				
Reflective	Threaded	 M3	Tough <small>Bending durability</small> FD-30	R2	2 m (Note 3)	STD 160 6.299 H-PWR 600 23.622	250 9.843 80 3.150 25 0.984	—	150 μm / ±3°	±10 %	IP67	-55 to +80 °C
		 M4	Tough <small>Bending durability</small> FD-40									
	Cylindrical	 M6	Tough <small>Bending durability</small> FD-60	R4		STD 520 20.472 H-PWR 1,550 61.024	740 29.134 260 10.236 90 3.543					
		 ø3	Tough <small>Bending durability</small> FD-S30			STD 160 6.299 H-PWR 600 23.622	250 9.843 80 3.150 25 0.984					

- Notes: 1) The fiber cable length practically limits the sensing range.
 2) The sensing range of reflective type is specified for white non-glossy paper.
 3) It is not a free-cut type.

LIST OF FIBERS

Tough : Refer to a fiber which possesses both unbreakable (bending radius: R10 mm R0.394 in, reciprocating bending: 180°) and more flexible (bending radius: R4 mm R0.157 in or less) features.
 Bending durability : Refer to a fiber which possesses unbreakable bending-resistant feature (bending radius: R10 mm R0.394 in, reciprocating bending: 180°).

Threaded type

*Thru-beam type sensors are available as two pieces per set.



Type	Shape of fiber head (mm)	Model No.	Bending radius (mm)	Fiber cable length Free-cut	Sensing range (mm in) (Note 1)			Beam axis dia. (mm)	Beam axis position / Inclination of beam axis	Protection	Ambient temp.
					FX-250 series	Other modes	LONG FAST H-SPD				
Thru-beam Threaded	M3 	Tough (Bending durability) FT-31	R2		STD 315 12.402 H-PWR 1,350 53.150	550 21.654 210 8.268 70 2.756	ø0.5	150 µm / ±2°	IP67	-55 to +80 °C	
		FT-31W	R1		STD 260 10.236 H-PWR 990 38.976						440 17.323 150 5.906 53 2.087
		Tough (Bending durability) FT-32	R2		STD 3,000 118.110 H-PWR (Note 2) 3,600 141.732			3,600 141.732 (Note 2) 1,600 62.992 580 22.835			150 µm / ±3°
	M4 	Lens mountable FT-43	(Bending durability)		R4	STD 1,400 55.118 H-PWR (Note 2) 3,600 141.732	2,100 82.677 770 30.315 240 9.449	ø1.5	150 µm / ±2°	IP67	-55 to +80 °C
		Lens mountable FT-42	Tough (Bending durability)		R4	STD 1,130 44.488 H-PWR (Note 2) 3,600 141.732	1,600 62.992 530 20.866 190 7.480				
		Lens mountable FT-42W	R1		STD 800 31.496 H-PWR (Note 2) 3,300 129.921	1,400 55.118 490 19.291 160 6.299	ø1	150 µm / ±3°			
		Lens mountable, Stainless-jacketed FT-45X	R4		1 m	STD 1,200 47.244 H-PWR (Note 2) 1,600 62.992	1,600 62.992 (Note 2) 630 24.803 200 7.874	150 µm / ±2°	-55 to +80 °C		
	M14 Long range	Elbow FT-R40	Tough (Bending durability)		R4	STD 930 36.614 H-PWR (Note 2) 3,600 141.732	1,500 59.055 500 19.685 160 6.299	ø10	—	IP67	-40 to +70 °C
		With expansion lens FT-140	Tough (Bending durability)		R4	STD (Note 2) 19,600 771.654 H-PWR (Note 2) 19,600 771.654	19,600 771.654 (Note 2) 16,000 629.921 6,300 248.031				

Notes: 1) Note that the sensing range of the free-cut type fiber may be reduced by 20 % max. depending upon how the fiber is cut.
 2) The fiber cable length practically limits the sensing range.

Tough : Refer to a fiber which possesses both unbreakable (bending radius: R10 mm **R0.394 in**, reciprocating bending: 180°) and more flexible (bending radius: R4 mm **R0.157 in** or less) features.
Bending durability : Refer to a fiber which possesses unbreakable bending-resistant feature (bending radius: R10 mm **R0.394 in**, reciprocating bending: 180°).

LIST OF FIBERS

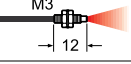
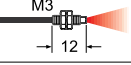
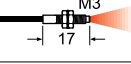
Threaded type

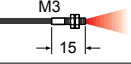
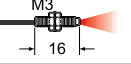
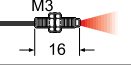
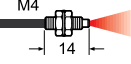
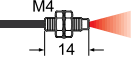
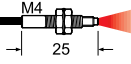
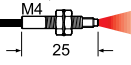
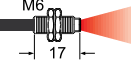
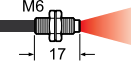
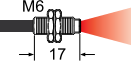
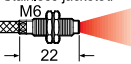
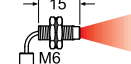
Type	Shape of fiber head (mm)	Model No.	Bending radius (mm)	Fiber cable length Free-cut	Sensing range (mm in) (Note 1, 2)			Beam axis position / Inclination of beam axis	Protection	Ambient temp.		
					FX-250 series		Other modes					
Reflective Threaded	M3	 Tough (Bending durability) FD-31	R2	2 m	STD 125 4.921 H-PWR 515 20.276	220 8.661 80 3.150 25 0.984	150 μm / ±3°	IP67	-55 to +80 °C			
		 FD-31W	R1		STD 80 3.150 H-PWR 330 12.992	140 5.512 45 1.772 12 0.472				-40 to +60 °C		
		 Tough (Bending durability) FD-32G	R2		STD 200 7.874 H-PWR 650 25.591	270 10.630 95 3.740 27 1.063					-55 to +80 °C	
		 FD-32GX	R2		STD 200 7.874 H-PWR 630 24.803	360 14.173 100 3.937 30 1.181						-40 to +70 °C
		 Tough (Bending durability) FD-34G	R2		STD 90 3.543 H-PWR 330 12.992	135 5.305 49 1.929 15 0.591						
	Ultra-small diameter	 FD-EG30	R4	500 mm	STD 48 1.890 H-PWR 170 6.693	110 4.331 30 1.181 9 0.354	-40 to +60 °C					
		 FD-EG31			STD 20 0.787 H-PWR 85 3.346	35 1.378 12 0.472 3.5 0.138						
	M4	 Tough (Bending durability) FD-41	R2	2 m	STD 125 4.921 H-PWR 515 20.276	220 8.661 80 3.150 25 0.984	150 μm / ±3°	IP67	-55 to +80 °C			
		 FD-41W	R1		STD 270 10.630 H-PWR 900 35.433	430 16.929 150 5.906 45 1.772				-40 to +60 °C		
		 Tough (Bending durability) FD-42G	R2		STD 200 7.874 H-PWR 650 25.591	270 10.630 95 3.740 27 1.063					-55 to +80 °C	
		 FD-42GW	R1		STD 150 5.906 H-PWR 670 26.378	280 11.024 90 3.543 25 0.984						-40 to +60 °C
	M6	 (Bending durability) FD-62	R4	1 m	STD 520 20.472 H-PWR 1,500 59.055	940 37.008 340 13.386 110 4.331	150 μm / ±3°	IP67	-55 to +80 °C			
		 Tough (Bending durability) FD-61			STD 450 17.717 H-PWR 1,400 55.118	670 26.378 200 7.874 70 2.756						
		 FD-61W	R1		STD 270 10.630 H-PWR 900 35.433	430 16.929 150 5.906 45 1.772				-40 to +60 °C		
		 FD-64X	R4		STD 280 11.024 H-PWR 670 26.378	410 16.142 160 6.299 50 1.969					-55 to +80 °C	
Elbow	 Tough (Bending durability) FD-R60	R4	2 m	STD 290 11.417 H-PWR 1,100 43.307	550 21.654 190 7.480 65 2.559	150 μm / ±3°	IP67	-55 to +80 °C				











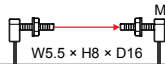

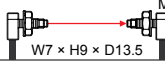

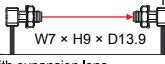
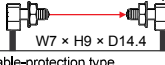
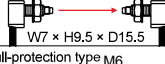

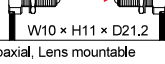

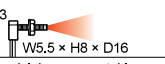
- Notes: 1) Note that the sensing range of the free-cut type fiber may be reduced by 20 % max. depending upon how the fiber is cut.
 2) The sensing range is specified for white non-glossy paper.
 3) The allowable cutting range is 700 mm **27.559 in** from the end that the amplifier inserted.

LIST OF FIBERS

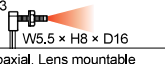
Tough : Refer to a fiber which possesses both unbreakable (bending radius: R10 mm R0.394 in, reciprocating bending: 180°) and more flexible (bending radius: R4 mm R0.157 in or less) features.
 : Refer to a fiber which possesses unbreakable bending-resistant feature (bending radius: R10 mm R0.394 in, reciprocating bending: 180°).

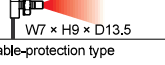
Square head type

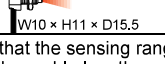
*Thru-beam type sensors are available as two pieces per set.

Type	Shape of fiber head (mm)	Model No.	Bending radius (mm)	Fiber cable length  : Free-cut	Sensing range (mm in) (Note 1, 3)			Beam axis dia. (Fiber Core) (mm)	Protection	Ambient temp.	
					FX-250 series	Other modes	LONG FAST H-SPD				
Thru-beam Square head	M3 	Tough  FT-R31	R2	 2 m	STD 270 10.630 H-PWR 1,000 39.370		440 17.323 160 6.299 55 2.165	ø0.5	IP67	-55 to +80 °C	
	Lens mountable M4 	Tough  FT-R43	R4		STD 720 28.346 H-PWR 3,000 118.110		1,100 43.307 430 16.929 130 5.118	ø1			
	Lens mountable (FX-LE2) M4 	FT-R41W	R1		STD 800 31.496 H-PWR 3,200 125.984		1,400 55.118 460 18.110 150 5.906	ø2.2	IP40	-40 to +60 °C	
	With expansion lens M4 	FT-R42W			STD 2,200 86.614 H-PWR (Note2) 3,600 141.732		3,500 137.795 1,300 51.181 460 18.110				
	Oil-resistant Cable-protection type Lens mountable M4 	Tough  FT-R44Y	R4		STD 720 28.346 H-PWR 3,000 118.110		1,100 43.307 430 16.929 130 5.118	ø1	IP67 (Note 4)	-55 to +80 °C	
	Oil-resistant Full-protection type M6 	Tough  FT-R60Y	R4		STD 2,100 82.677 H-PWR (Note2) 3,600 141.732		3,600 141.732 (Note 2) 1,260 49.606 400 15.748	ø3.5	IP68G		
Reflective Square head	Coaxial, Lens mountable M3 	Tough  FD-R31G	R2	 2 m	STD 170 6.693 H-PWR 530 20.866		260 10.236 85 3.346 27 1.063	Emitter ø0.5	IP40	-55 to +80 °C	
	Coaxial, Lens mountable M3 	FD-R32EG	R4		STD 145 1.772 H-PWR 170 6.693		92 3.622 30 1.181 9 0.354	Emitter ø0.25			
	Coaxial, Lens mountable M3 	FD-R34EG			STD 138 1.496 H-PWR 130 5.118		70 2.756 23 0.906 7 0.276	Emitter ø0.175			
	Coaxial, Lens mountable M3 	FD-R33EG			STD 19 0.748 H-PWR 84 3.307		33 1.299 11 0.433 3 0.118	Emitter ø0.125			
	Coaxial, Lens mountable M4 	Tough  FD-R41			R2	STD 210 8.268 H-PWR 710 27.953		320 12.598 100 3.937 34 1.339	ø0.75	IP67	-55 to +80 °C
	Oil-resistant Cable-protection type M6 	Tough  FD-R61Y			R4	STD 280 11.024 H-PWR 990 38.976		435 17.126 160 6.299 50 1.969	—	IP67 (Note 4)	







- Notes: 1) Note that the sensing range of the free-cut type fiber may be reduced by 20 % max. depending upon how the fiber is cut.
 2) The fiber cable length practically limits the sensing range.
 3) The sensing range of reflective type is specified for white non-glossy paper.
 4) The fiber part is oil-resistant.

Tough : Refer to a fiber which possesses both unbreakable (bending radius: R10 mm **R0.394 in**, reciprocating bending: 180°) and more flexible (bending radius: R4 mm **R0.157 in** or less) features.
Bending durability : Refer to a fiber which possesses unbreakable bending-resistant feature (bending radius: R10 mm **R0.394 in**, reciprocating bending: 180°).

LIST OF FIBERS

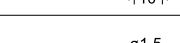
Cylindrical type

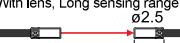
*Thru-beam type sensors are available as two pieces per set.

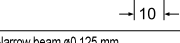
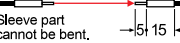
Type	Shape of fiber head (mm)	Model No.	Bending radius (mm)	Fiber cable length (mm)	Sensing range (mm in) (Note 1 ,3)			Beam axis dia. (mm)	Beam axis position / Inclination of beam axis	Protection	Ambient temp.	
					FX-250 series	Other modes	LONG FAST H-SPD					
Thru-beam Cylindrical		Tough Bending durability FT-S11	R2	500 mm	STD 90 3.543 H-PWR 60 2.362 1350 13.780		160 6.299 60 2.362 19 0.748	ø0.25	—	IP67	-55 to +80 °C	
		Tough Bending durability FT-S21			STD 315 12.402 H-PWR 210 8.268 70 2.756 1,350 53.150	550 21.654 210 8.268 70 2.756						
		FT-S21W	R1	2 m	STD 260 10.236 H-PWR 990 38.976		440 17.323 150 5.906 53 2.087	ø0.5	150 µm / ±2°	IP67	-40 to +60 °C	
		Tough Bending durability FT-S22			STD 450 17.717 H-PWR 1,500 59.055	730 28.740 250 9.843 90 3.543						
		Bending durability FT-S32	R10	2 m	STD 3,100 122.047 H-PWR (Note 2) 3,600 141.732		3,600 141.732 (Note 2) 1,800 70.866 600 23.622	ø2	—	IP40	-40 to +70 °C	
		Tough Bending durability FT-S31W			STD 800 31.496 H-PWR 490 19.291 160 6.299 3,300 129.921	1,400 55.118 490 19.291 160 6.299						
	Side-view Ultra-small diameter		Tough Bending durability FT-E13	R2	1 m	STD 15 0.591 H-PWR 52 2.047		24 0.945 8 0.315 2 0.079	ø0.125	150 µm / ±3°	IP67	-40 to +70 °C
			Tough Bending durability FT-E23			STD 75 2.953 H-PWR 42 1.654 270 10.630	125 4.921 42 1.654 13 0.512					
			Tough Bending durability FT-V40	R4	2 m	STD 3,500 137.795 H-PWR (Note 2) 3,600 141.732		3,600 141.732 (Note 2) 2,400 94.488 850 33.465	ø2.5	—	IP50	-40 to +60 °C
Reflective Cylindrical		Tough Bending durability FD-S23 NEW	R2	1 m	STD 46 1.811 H-PWR 130 5.118		65 2.559 20 0.787 7 0.276	—	150 µm / ±3°	IP40	-55 to +80 °C	
		Tough Bending durability FD-S32	R4	STD 420 16.535 H-PWR 1,200 47.244	660 25.984 220 8.661 75 2.953							
		FD-S32W	R1	2 m	STD 270 10.630 H-PWR 900 35.433		430 16.929 150 5.906 45 1.772	—	150 µm / ±3°	IP67	-40 to +60 °C	
		Tough Bending durability FD-S31	R2		STD 125 4.921 H-PWR 515 20.276	220 8.661 80 3.150 25 0.984						
		FD-S33GW	R1	1 m	STD 150 5.906 H-PWR 670 26.378		280 11.024 90 3.543 25 0.984	—	150 µm / ±3°	IP40	-40 to +60 °C	
		Tough Bending durability FD-S34G	R2		STD 90 3.543 H-PWR 330 12.992	135 5.305 49 1.929 15 0.591						
	Ultra-small diameter		FD-E13	R4	1 m	STD 12 0.472 H-PWR 50 1.969		25 0.984 7 0.276 2 0.079	—	150 µm / ±3°	IP40	-40 to +60 °C
			Tough Bending durability FD-E23			STD 55 2.165 H-PWR 30 1.181 170 6.693	80 3.150 9 0.354					

- Notes: 1) Note that the sensing range of the free-cut type fiber may be reduced by 20 % max. depending upon how the fiber is cut.
 2) The fiber cable length practically limits the sensing range.
 3) The sensing range of reflective type is specified for white non-glossy paper.

Tough : Refer to a fiber which possesses both unbreakable (bending radius: R10 mm R0.394 in, reciprocating bending: 180°) and more flexible (bending radius: R4 mm R0.157 in or less) features.
Bending durability : Refer to a fiber which possesses unbreakable bending-resistant feature (bending radius: R10 mm R0.394 in, reciprocating bending: 180°).

LIST OF FIBERS

Sleeve type

*Thru-beam type sensors are available as two pieces per set.

Type	Shape of fiber head (mm)	Model No.	Bending radius (mm)	Fiber cable length (mm) Free-cut	Sensing range (mm in) (Note 1, 4)		Beam axis dia. (mm)	Protection	Ambient temp.	
					FX-250 series	Other modes LONG FAST H-SPD				
Thru-beam Threaded	M3 	Tough (Bending durability) FT-31S	R2 (Note 2)	2 m	STD 315 12.402 H-PWR 1,220 48.031	550 21.654 195 7.677 63 2.480	∅0.5	IP67	-55 to +80 °C	
	M4 	Tough (Bending durability) FT-42S	R4 (Note 2)	2 m	STD 1,130 44.488 H-PWR (Note 3) 3,600 141.732	1,600 62.992 530 20.866 190 7.480	∅1			
Thru-beam Cylindrical	Ultra-small diameter ∅3 	Tough (Bending durability) FT-E13	R2	1 m	STD 15 0.591 H-PWR 52 2.047	24 0.945 8 0.315 2 0.079	∅0.125	IP67	-40 to +70 °C	
	Ultra-small diameter ∅3 	Tough (Bending durability) FT-E23			STD 175 2.953 H-PWR 42 1.654 270 10.630	125 4.921 42 1.654 13 0.512	∅0.25			
	Side-view ∅2 	Tough (Bending durability) FT-V23	R4	2 m	STD 450 17.717 H-PWR 1,800 70.866	880 34.646 280 11.024 90 3.543	∅0.75	IP30	-55 to +80 °C	
	Side-view ∅2 	Tough (Bending durability) FT-V25	R2		STD 240 9.449 H-PWR 900 35.433	480 18.898 140 5.512 45 1.772	∅0.5			
Side-view ∅2 	Tough (Bending durability) FT-V24W	R1	STD 110 4.331 H-PWR 380 14.961		200 7.874 60 2.362 20 0.787	∅0.5				
Side-view ∅2.5 	Tough (Bending durability) FT-V30	R4	STD 680 26.772 H-PWR 2,200 86.614		1,000 39.370 340 13.386 100 3.937	∅1.0				
Thru-beam Threaded	Ultra-small diameter M3 	Tough (Bending durability) FD-EG30S	R4	1 m	STD 50 1.969 H-PWR 170 6.693	80 3.150 30 1.181 9 0.354	—	IP40	-40 to +70 °C	
	M4 	Tough (Bending durability) FD-41S	R2 (Note 2)	2 m	STD 125 4.921 H-PWR 515 20.276	220 8.661 80 3.150 25 0.984	IP67			-55 to +80 °C
	M4 	Tough (Bending durability) FD-41SW	R1 (Note 2)		STD 80 3.150 H-PWR 330 12.992	140 5.512 45 1.772 12 0.472				
M6 	Tough (Bending durability) FD-61S	R4 (Note 2)	2 m	STD 420 16.535 H-PWR 1,200 47.244	660 25.984 220 8.661 75 2.953	—	IP67	-55 to +80 °C		
Reflective Cylindrical	Ultra-small diameter ∅1.5 	Tough (Bending durability) FD-E13	R4	1 m	STD 12 0.472 H-PWR 50 1.969	25 0.984 7 0.276 2 0.079	—	IP40	-40 to +60 °C	
	Ultra-small diameter ∅3 	Tough (Bending durability) FD-E23			STD 55 2.165 H-PWR 170 6.693	80 3.150 30 1.181 9 0.354				
	Side-view ∅3 	Tough (Bending durability) FD-V30	R2	2 m	STD 65 2.559 H-PWR 240 9.449	120 4.724 35 1.378 14 0.551	IP30	-55 to +80 °C		
	Side-view ∅3 	Tough (Bending durability) FD-V30W	R1		STD 20 0.787 H-PWR 80 3.150	30 1.181 10 0.394 2 0.079				
	Side-view ∅5 	Tough (Bending durability) FD-V50	R4		STD 120 4.724 H-PWR 370 14.567	210 8.268 75 2.953 25 0.984				

- Notes: 1) Note that the sensing range of the free-cut type fiber may be reduced by 20 % max. depending upon how the fiber is cut.
- 2) Bending radius of sleeve part is R10 mm R0.394 in or more.
- 3) The fiber cable length practically limits the sensing range.
- 4) The sensing range of reflective type is specified for white non-glossy paper.

Tough : Refer to a fiber which possesses both unbreakable (bending radius: R10 mm **R0.394 in**, reciprocating bending: 180°) and more flexible (bending radius: R4 mm **R0.157 in** or less) features.
Bending durability : Refer to a fiber which possesses unbreakable bending-resistant feature (bending radius: R10 mm **R0.394 in**, reciprocating bending: 180°).

LIST OF FIBERS

Flat type

*Thru-beam type sensors are available as two pieces per set.

Type	Shape of fiber head (mm)	Model No.	Bending radius (mm)	Fiber cable length Free-cut	Sensing range (mm in) (Note 1, 3)			Beam axis dia. (mm)	Protection	Ambient temp.			
					FX-250 series	Other modes	LONG FAST H-SPD						
Thru-beam	Flat	Top sensing W3 × H8 × D12 Tough (Bending durability)	FT-Z30H	R2	Free-cut	STD 3,500 137.795	3,600 141.732 (Note 2)	2 × 3	IP40	-40 to +60 °C			
		Top sensing W3 × H8 × D12	FT-Z30HW	R1		H-PWR (Note 2) 3,600 141.732					2,600 102.362 810 31.890		
	Side sensing W3 × H12 × D8 Tough (Bending durability)	FT-Z30E	R2	STD 3,500 137.795		3,600 141.732 (Note 2)							
	Side sensing W3 × H12 × D8	FT-Z30EW	R1	H-PWR (Note 2) 3,600 141.732			2,400 94.488 740 29.134						
	Front sensing W8.5 × H12 × D3 Tough (Bending durability)	FT-Z30	R2	STD 3,400 133.858		3,600 141.732 (Note 2)							
	Front sensing W8.5 × H12 × D3	FT-Z30W	R1	H-PWR (Note 2) 3,600 141.732			2,000 78.740 630 24.803						
	With boss	Front sensing W8.5 × H12 × D3	FT-Z30W	R1		STD 1,500 59.055	3,200 125.984 1,000 39.370 280 11.024				ø2	IP40	-40 to +60 °C
		Front sensing W10 × H7 × D2	FT-Z20W	R1		STD 620 24.409							
		Fiber guide type W2 × H10 × D10	FT-Z20HBW	R1		H-PWR (Note 2) 1,600 62.992	1,100 43.307 420 16.535 130 5.118						
		Front sensing W14 × H7 × D3.5	FT-Z40W	R1		STD 1,500 59.055	2,300 90.551 900 35.433 290 11.417						
Fiber guide type W3.5 × H14 × D11		FT-Z40HBW	R1	H-PWR (Note 2) 3,600 141.732	1,400 55.118 490 19.291 160 6.299								
Chemical-resistant		Easy mounting, Rectangular head SEMI S2 compliant (Note 4) Metal-free W7 × H15 × D13 Tough (Bending durability)	FT-Z802Y	R4	STD 3,100 122.047	3,600 141.732 (Note 2)	ø3.7	IP68G	0 to +60 °C				
			H-PWR (Note 2) 3,600 141.732	1,900 74.803 470 18.504									
Reflective	Flat	Front sensing W10 × H7 × D2	FD-Z20W	R1	STD 1 to 65 0.039 to 2.559	130 5.118 2 to 45 0.079 to 1.772 5 to 13 0.197 to 0.512				IP40	-40 to +60 °C		
		Fiber guide type W2 × H10 × D10	FD-Z20HBW	R1	STD 2 to 85 0.079 to 3.346							1 to 180 0.039 to 7.087 2 to 55 0.079 to 2.165 3 to 15 0.118 to 0.591	
		Front sensing W14 × H7 × D3.5	FD-Z40W	R1	H-PWR 1 to 340 0.039 to 13.386								390 15.354 1 to 120 0.039 to 4.724 2 to 35 0.079 to 1.378
		Fiber guide type W3.5 × H14 × D11	FD-Z40HBW	R1	STD 190 7.480							760 29.921	
	With boss	Front sensing W10 × H7 × D2	FD-Z20W	R1	STD 260 10.236	1 to 180 0.039 to 7.087 2 to 55 0.079 to 2.165 3 to 15 0.118 to 0.591	IP67						
		Fiber guide type W2 × H10 × D10	FD-Z20HBW	R1	STD 2 to 85 0.079 to 3.346			1 to 340 0.039 to 13.386					
		Front sensing W14 × H7 × D3.5	FD-Z40W	R1	H-PWR 1 to 340 0.039 to 13.386				390 15.354 1 to 120 0.039 to 4.724 2 to 35 0.079 to 1.378				
		Fiber guide type W3.5 × H14 × D11	FD-Z40HBW	R1	STD 190 7.480			760 29.921					

Notes: 1) Note that the sensing range of the free-cut type fiber may be reduced by 20 % max. depending upon how the fiber is cut.

2) The fiber cable length practically limits the sensing range.



3) The sensing range of reflective type is specified for white non-glossy paper.

4) The design takes into account the environmental testing required by SEMI S2. To ensure that the final system complies with the standards, you must design and use it in accordance with relevant standards, laws, and regulations.

Tough : Refer to a fiber which possesses both unbreakable (bending radius: R10 mm **R0.394 in**, reciprocating bending: 180°) and more flexible (bending radius: R4 mm **R0.157 in** or less) features.
Bending durability : Refer to a fiber which possesses unbreakable bending-resistant feature (bending radius: R10 mm **R0.394 in**, reciprocating bending: 180°).

LIST OF FIBERS

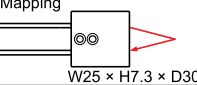
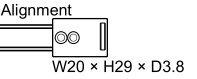
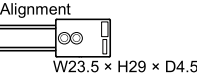
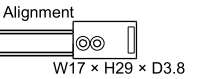
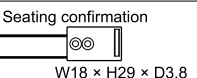
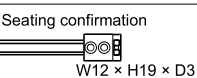
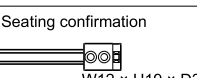
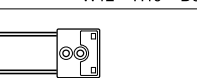
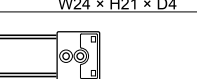
Convergent reflective type

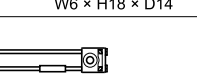
Type	Shape of fiber head (mm)	Model No.	Bending radius (mm)	Fiber cable length Free-cut	Sensing range (mm in) (Note 1, 2)			Protection	Ambient temp.
					FX-250 series	Other modes	LONG FAST H-SPD		
Convergent reflective	Glass substrate detection	 Mapping W25 × H7.3 × D3.0 Bending durability FD-L32H	R4	4 m	STD 0 to 56 0 to 2.205 H-PWR 0 to 110 0 to 4.331	0 to 74 1 to 38	0 to 2.913 0.039 to 1.496 Cannot use	IP40	-40 to +60 °C
		 Alignment W20 × H29 × D3.8 Tough Bending durability FD-L30A	R2	3 m	STD 0 to 43 0 to 1.693 H-PWR 0 to 43 0 to 1.693	0 to 43 0 to 42 0 to 29	0 to 1.693 0 to 1.654 0 to 1.142		0 to +70 °C
		 Alignment W23.5 × H29 × D4.5 Tough Bending durability FD-L31A	R4		STD 4 to 33 0.157 to 1.299 H-PWR 3 to 35 0.118 to 1.378	4 to 33 4 to 32 5 to 25	0.157 to 1.299 0.157 to 1.260 0.197 to 0.984		
		 Alignment W17 × H29 × D3.8 Tough Bending durability FD-L24A	R2	2 m	STD 0 to 23 0 to 0.906 H-PWR 0 to 31 0 to 1.220	0 to 26 0 to 22 0 to 18	0 to 1.024 0 to 0.866 0 to 0.709		-20 to +70 °C
		 Seating confirmation W18 × H29 × D3.8 Tough Bending durability FD-L25			3 m	STD 0 to 29 0 to 1.142 H-PWR 0 to 30 0 to 1.181	0 to 30 0 to 28 2 to 23		
		 Seating confirmation W12 × H19 × D3 Tough Bending durability FD-L11	R4	2 m	STD 0 to 9.5 0 to 0.374 H-PWR 0 to 11.5 0 to 0.453	0 to 10 0 to 9 0 to 8	0 to 0.394 0 to 0.354 0 to 0.315		-40 to +60 °C
		 Seating confirmation W12 × H19 × D3 Tough Bending durability FD-L10			STD 0 to 5 0 to 0.197 H-PWR 0 to 6 0 to 0.236	0 to 5.5 0 to 4.5 0 to 4	0 to 0.217 0 to 0.177 0 to 0.157		
		 Seating confirmation W24 × H21 × D4 Tough Bending durability FD-L21			R2	STD 1.5 to 16 0.059 to 0.630 H-PWR 1 to 19 0.039 to 0.748	1 to 18 2 to 15 3 to 12		
		 Seating confirmation W24 × H21 × D4 Tough Bending durability FD-L21W	R1	STD 3 to 14 0.118 to 0.551 H-PWR 1.5 to 15 0.059 to 0.591	2 to 15 4 to 14 6.5 to 10	0.079 to 0.591 0.157 to 0.551 0.256 to 0.394			
		 General purpose W6 × H18 × D14 Tough Bending durability FD-L20H	R2	STD 0 to 23 0 to 0.906 H-PWR 0 to 45 0 to 1.772	0 to 32 2 to 15 5 to 9	0 to 1.260 0.079 to 0.591 0.197 to 0.354	-40 to +70 °C		
 Ultra-small W7.2 × H7.5 × D2 Tough Bending durability FD-L12W	R1	1 m	STD 0 to 8 0 to 0.315 H-PWR 0 to 14 0 to 0.551	0 to 12 0.5 to 7 0.5 to 4	0 to 0.472 0.020 to 0.276 0.020 to 0.157	IP30	-40 to +60 °C		

Notes: 1) Note that the sensing range of the free-cut type fiber may be reduced by 20 % max. depending upon how the fiber is cut.
 2) The sensing range is specified for transparent glass 100 × 100 × 0.7 mm **3.937 × 3.937 × t0.028 in** (FD-L32H: R edge, FD-L21 and FD-L21W: t2 mm **t0.079 in**) (FD-L20H: white non-glossy paper, FD-L10: silicon wafers 100 × 100 mm **3.937 × 3.937 in**).

Tough : Refer to a fiber which possesses both unbreakable (bending radius: R10 mm **R0.394 in**, reciprocating bending: 180°) and more flexible (bending radius: R4 mm **R0.157 in** or less) features.
Bending durability : Refer to a fiber which possesses unbreakable bending-resistant feature (bending radius: R10 mm **R0.394 in**, reciprocating bending: 180°).

LIST OF FIBERS

Small spot

Reflective type fiber & spot lens

Designation	Shape of head (mm)	Spot diameter (mm in) (Note 1)	Sensing range (mm in) (Note 1)	Lens		Applicable fibers						
				Model No.	Ambient temp.	Model No.	Fiber cable length Free-cut (Note 2)	Bending radius (mm)	Protection	Ambient temp.		
Finest spot lens		ø0.1 ø0.004 approx.	Distance to focal point 7 ±0.5 0.276 ±0.020	FX-MR7	-55 to +70 °C	FD-R33EG	500 mm	R4	IP40		-20 to +60 °C	
						FD-EG31						
		FD-R34EG										
		FD-R32EG										
		FD-EG30				2 m	R2	-40 to +70 °C				
		Tough Bending durability FD-R31G										
		Tough Bending durability FD-42G										
		FD-42GW										
		Tough Bending durability FD-32G				1 m (Note 3)	R2					-55 to +80 °C
		FD-32GX										
	ø0.4 ø0.016 approx.	Distance to focal point 7 ±0.5 0.276 ±0.020	FX-MR6	-20 to +60 °C	FD-R33EG	500 mm	R4		IP40		-20 to +60 °C	
					FD-EG31							
	FD-R34EG											
	FD-R32EG											
	FD-EG30				2 m	R2	-40 to +70 °C					
	Tough Bending durability FD-R31G											
	Tough Bending durability FD-42G											
	FD-42GW											
	Tough Bending durability FD-32G				1 m (Note 3)	R2		-55 to +80 °C				
	FD-32GX											



- Notes: 1) Spot diameter, sensing range and distance to focal point are specified for **FX-250** series.
 2) Note that the sensing range of the free-cut type fiber may be reduced by 20 % max. depending upon how the fiber is cut.
 3) The allowable cutting range is 700 mm **27.559 in** from the end that the amplifier inserted.

Tough : Refer to a fiber which possesses both unbreakable (bending radius: R10 mm R0.394 in, reciprocating bending: 180°) and more flexible (bending radius: R4 mm R0.157 in or less) features.
 : Refer to a fiber which possesses unbreakable bending-resistant feature (bending radius: R10 mm R0.394 in, reciprocating bending: 180°).

LIST OF FIBERS

Small spot

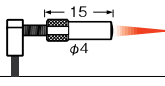
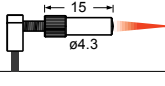
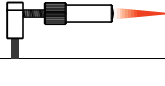
Reflective type fiber & spot lens

Designation	Shape of head (mm)	Spot diameter (mm in) (Note 1)	Sensing range (mm in) (Note 1)	Lens		Applicable fibers										
				Model No.	Ambient temp.	Model No.	Fiber cable length  : Free-cut (Note 2)	Bending radius (mm)	Protection	Ambient temp.						
Finest spot lens		ø0.15 ø0.006 approx.	Distance to focal point 7.5 ±0.5 0.295 ±0.020	FX-MR3	-40 to +70 °C	FD-R33EG	500 mm	R4	IP40	-20 to +60 °C						
		ø0.2 ø0.008 approx.				FD-EG31										
	ø0.3 ø0.012 approx.	FD-R34EG														
		FD-R32EG														
	ø0.5 ø0.020 approx.	FD-EG30														
	Zoom lens					ø0.4 to ø2.0 ø0.016 to ø0.079 approx.	10 to 30 0.394 to 1.181	FX-MR8			-55 to +70 °C	FD-R33EG	500 mm	R4	IP40	-20 to +60 °C
						ø0.4 to ø2.2 ø0.016 to ø0.087 approx.						FD-EG31				
		ø0.5 to ø2.5 ø0.020 to ø0.098 approx.				FD-R34EG										
						FD-R32EG										
		ø0.8 to ø3.5 ø0.031 to ø0.138 approx.				FD-EG30										
Zoom lens		ø0.8 to ø3.5 ø0.031 to ø0.138 approx.	ø0.8 to ø3.5 ø0.031 to ø0.138 approx.	FX-MR8	-55 to +70 °C	Tough (Bending durability) FD-R31G	2 m	R2	IP40	-55 to +80 °C						
						Tough (Bending durability) FD-42G										
	FD-42GW															
	Tough (Bending durability) FD-32G															
Zoom lens		ø0.8 to ø3.5 ø0.031 to ø0.138 approx.	ø0.8 to ø3.5 ø0.031 to ø0.138 approx.	FX-MR8	-55 to +70 °C	FD-32GX	1 m (Note 3)	R2	IP40	-55 to +80 °C						
						FD-32G	2 m	R2								

Notes: 1) Spot diameter, sensing range and distance to focal point are specified for FX-250 series.
 2) Note that the sensing range of the free-cut type fiber may be reduced by 20 % max. depending upon how the fiber is cut.
 3) The allowable cutting range is 700 mm 27.559 in from the end that the amplifier inserted.

Tough : Refer to a fiber which possesses both unbreakable (bending radius: R10 mm **R0.394 in**, reciprocating bending: 180°) and more flexible (bending radius: R4 mm **R0.157 in** or less) features.
Bending durability : Refer to a fiber which possesses unbreakable bending-resistant feature (bending radius: R10 mm **R0.394 in**, reciprocating bending: 180°).

LIST OF FIBERS

Small spot

Reflective type fiber & spot lens

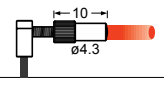
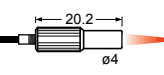
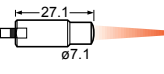
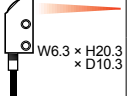
Designation	Shape of head (mm)	Spot diameter (mm in) (Note 1)	Sensing range (mm in) (Note 1)	Lens		Applicable fibers							
				Model No.	Ambient temp.	Model No.	Fiber cable length ✂: Free-cut (Note 2)	Bending radius (mm)	Protection	Ambient temp.			
Parallel light lens		ø4 ø0.157 approx.	0 to 30 0 to 1.181	FX-MR9	-55 to +70 °C	FD-R33EG	500 mm	R4	IP40		-20 to +60 °C		
						FD-EG31							
						FD-R34EG							
						FD-R32EG							
						FD-EG30	✂	2 m				R2	-40 to +70 °C
						Tough Bending durability FD-R31G							
						Tough Bending durability FD-42G							
						FD-42GW							
						Tough Bending durability FD-32G							
						FD-32GX							
Pinpoint spot lens		ø0.5 ø0.020	Distance to focal point 6 ±1 0.236 ±0.039	FX-MR1	-40 to +70 °C	Tough Bending durability FD-42G	✂	2 m	R2	-55 to +80 °C			
						FD-42GW					R1	-40 to +60 °C	
						Zoom lens						ø0.7 to ø2.0 ø0.028 to ø0.079 approx.	Distance to focal point 18.5 to 43 0.728 to 1.693 approx.
FD-42GW	R1	-40 to +60 °C											
Zoom lens (Side-view type)		ø0.5 to ø3.0 ø0.020 to ø0.118 approx.	Distance to focal point 13 to 30 0.512 to 1.181 approx.	FX-MR5	-40 to +60 °C	Tough Bending durability FD-42G	✂		R2	-55 to +80 °C			
FD-42GW	R1	-40 to +60 °C											

- Notes: 1) Spot diameter, sensing range and distance to focal point are specified for FX-250 series.
 2) Note that the sensing range of the free-cut type fiber may be reduced by 20 % max. depending upon how the fiber is cut.
 3) The allowable cutting range is 700 mm **27.559 in** from the end that the amplifier inserted.

LIST OF FIBERS

Tough : Refer to a fiber which possesses both unbreakable (bending radius: R10 mm R0.394 in, reciprocating bending: 180°) and more flexible (bending radius: R4 mm R0.157 in or less) features.
Bending durability : Refer to a fiber which possesses unbreakable bending-resistant feature (bending radius: R10 mm R0.394 in, reciprocating bending: 180°).

Narrow beam

*Thru-beam type sensors are available as two pieces per set.

Type	Shape of fiber head (mm)	Model No.	Bending radius (mm)	Fiber cable length Free-cut	Sensing range (mm in) (Note 1, 3, 4)			Beam axis dia. (mm)	Inclination of beam axis	Protection	Ambient temp.	
					FX-250 series		Other modes					
Thru-beam Narrow beam Side-view	Aperture angle 2° 	Tough (Bending durability) FT-KS40	R2		STD 3,600 141.732	3,600 141.732 (Note 2) 3,600 141.732 (Note 2) 1,200 47.244	ø2.2	—	IP40	-40 to +80 °C		
	H-PWR 3,600 141.732											
	Aperture angle 2° 	Tough (Bending durability) FT-KV40	R1		STD 3,600 141.732	3,600 141.732 (Note 2) 3,100 122.047 (Note 2) 940 37.008	ø2.5	±0.8°	IP30	-40 to +60 °C		
	H-PWR 3,600 141.732											
	Aperture angle 2° 	Tough (Bending durability) FT-KV40W	R2		STD 3,600 141.732	3,600 141.732 (Note 2) 3,100 122.047 940 37.008	ø1	X ±1° Z ±0.5°	IP30	-40 to +80 °C		
H-PWR 3,600 141.732												
Aperture angle 3° 	Tough (Bending durability) FT-KV26	R10	STD 710 27.953	1,200 47.244 440 17.323 160 6.299	ø1	X ±1° Z ±0.5°	IP30	-40 to +80 °C				
H-PWR 2,500 98.425												
Aperture angle 3° 	Tough (Bending durability) FT-KV26H1		STD 630 24.803	1,070 42.126 390 15.354 135 5.315				-40 to +105 °C				
H-PWR 2,200 86.614												
Retroreflective Ultra-narrow beam Narrow beam Side sensing	W5.2 × H9.5 × D16 	Tough (Bending durability) FR-Z50HW	R1		STD 100 to 990 3.937 to 38.976	100 to 1,200 3.937 to 47.244 100 to 780 3.937 to 30.709 100 to 490 3.937 to 19.291	—	—	IP40	-25 to +55 °C		
	H-PWR 100 to 1,900 3.937 to 74.803											
	W7.5 × H2.2 × D11.2 	Tough (Bending durability) FR-KZ22E	R2		STD 15 to 310 0.591 to 12.205	15 to 410 0.591 to 16.142 15 to 220 0.591 to 8.661 15 to 100 0.591 to 3.937					IP30	-40 to +60 °C
	H-PWR 15 to 570 0.591 to 22.441											
W5.2 × H9.5 × D21 	Tough (Bending durability) FR-KZ50H		STD 20 to 300 0.787 to 11.811	20 to 400 0.787 to 15.748 20 to 200 0.787 to 7.874 20 to 200 0.787 to 7.874								
H-PWR 20 to 1,000 0.787 to 39.370												
W9.5 × H25 × D5.2 	Tough (Bending durability) FR-KZ50E											
Reflective Long range	W5.2 × H9.5 × D16 	FD-Z50HW	R1		STD 10 to 650 0.394 to 25.591	10 to 1,000 0.394 to 39.370 10 to 410 0.394 to 16.142 15 to 130 0.591 to 5.118	—	—	IP40	-40 to +60 °C		
H-PWR 10 to 2,500 0.394 to 98.425												

- Notes: 1) Note that the sensing range of the free-cut type fiber may be reduced by 20 % max. depending upon how the fiber is cut.
 2) The fiber cable length practically limits the sensing range.
 3) The sensing range of retroreflective type is the possible setting range for the attached reflector. The fiber can detect an object less than setting range for the reflector. Refer to the next page for the sensing range when **FR-Z50HW** is used in combination with a reflector (optional).
 4) The sensing range of reflective type is specified for white non-glossy paper.

Tough : Refer to a fiber which possesses both unbreakable (bending radius: R10 mm **R0.394 in**, reciprocating bending: 180°) and more flexible (bending radius: R4 mm **R0.157 in** or less) features.
Bending durability : Refer to a fiber which possesses unbreakable bending-resistant feature (bending radius: R10 mm **R0.394 in**, reciprocating bending: 180°).

LIST OF FIBERS

Wide beam

*Thru-beam type sensors are available as two pieces per set.



Type	Shape of fiber head (mm)	Model No.	Bending radius (mm)	Fiber cable length Free-cut	Sensing range (mm in) (Note 1, 4)			Beam axis dia. (mm)	Protection	Ambient temp.
					FX-250 series		Other modes			
Thru-beam	 Sensing width 32 mm W5 x H69 x D20	Tough <small>Bending durability</small> FT-A32 (Note 2)	R2	2 m	STD <small>(Note 3)</small> 3,600 141.732 H-PWR <small>(Note 3)</small> 3,600 141.732	3,600 141.732 <small>(Note 3)</small> 3,600 141.732 <small>(Note 3)</small> 2,100 82.677	3.2 x 32	IP40	-40 to +60 °C	
		Allows flexible wiring Sensing width 32 mm W5 x H69 x D20	FT-A32W (Note 2)		R1	STD <small>(Note 3)</small> 3,600 141.732 H-PWR <small>(Note 3)</small> 3,600 141.732				3,600 141.732 <small>(Note 3)</small> 3,600 141.732 <small>(Note 3)</small> 3,000 118.110
	 Sensing width 11 mm W4.2 x H31 x D13.5	Tough <small>Bending durability</small> FT-A11 (Note 2)	R2		STD <small>(Note 3)</small> 3,600 141.732 H-PWR <small>(Note 3)</small> 3,600 141.732	3,600 141.732 <small>(Note 3)</small> 3,600 141.732 <small>(Note 3)</small> 1,100 43.307	2.2 x 11		-40 to +70 °C	
		Allows flexible wiring Sensing width 11 mm W4.2 x H31 x D13.5	FT-A11W (Note 2)		R1	STD <small>(Note 3)</small> 3,600 141.732 H-PWR <small>(Note 3)</small> 3,600 141.732			3,600 141.732 <small>(Note 3)</small> 3,600 141.732 <small>(Note 3)</small> 1,300 51.181	-40 to +55 °C
	Array	 Sensing width 5.5 mm W5 x H15 x D15	Tough <small>Bending durability</small> FT-AL05		R2	STD 860 33.858 H-PWR 2,300 90.551	1,500 59.055 500 19.685 170 6.693		0.25 x 5.5	-55 to +80 °C
	Reflective	Wide beam	Tough <small>Bending durability</small> FD-A16		R4	STD 200 7.874 H-PWR Cannot use	200 7.874 140 5.512 75 2.953		—	IP40
Array		 W5 x H20 x D20 NEW	R2	STD 270 10.630 H-PWR 670 26.378	420 16.535 150 5.906 50 1.969	—	IP40	-55 to +80 °C		

- Notes: 1) Note that the sensing range of the free-cut type fiber may be reduced by 20 % max. depending upon how the fiber is cut.
 2) The slit mask (accessory) is sold separately. Refer to the last page for more details.
 3) The fiber cable length practically limits the sensing range.
 4) The sensing range of reflective type is specified for white non-glossy paper.

Tough : Refer to a fiber which possesses both unbreakable (bending radius: R10 mm R0.394 in, reciprocating bending: 180°) and more flexible (bending radius: R4 mm R0.157 in or less) features.
 : Refer to a fiber which possesses unbreakable bending-resistant feature (bending radius: R10 mm R0.394 in, reciprocating bending: 180°).

LIST OF FIBERS

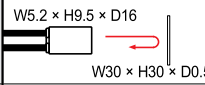
Retroreflective type

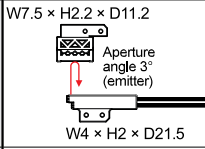
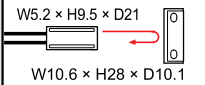
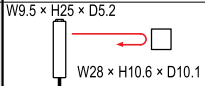
Type	Shape of fiber head (mm)	Model No.	Bending radius (mm)	Fiber cable length  : Free-cut	Sensing range (mm in) (Note 1, 2)			Protection	Ambient temp.
					FX-250 series	Other modes	LONG FAST H-SPD		
Retroreflective	With polarizing filters  W5.2 × H9.5 × D16 W30 × H30 × D0.5	FR-Z50HW	R1	 : 2 m	STD 100 to 990 3.937 to 38.976	100 to 1,200 3.937 to 47.244 100 to 780 3.937 to 30.709 100 to 490 3.937 to 19.291	LONG FAST H-SPD	IP40	-25 to +55 °C
	Ultra-narrow beam  W7.5 × H2.2 × D11.2 Aperture angle 3° (emitter) W4 × H2 × D21.5	Tough (Bending durability) FR-KZ22E	STD 15 to 310 0.591 to 12.205 H-PWR 15 to 570 0.591 to 22.441		15 to 410 0.591 to 16.142 15 to 220 0.591 to 8.661 15 to 100 0.591 to 3.937				
	Narrow beam Top sensing  W5.2 × H9.5 × D21 W10.6 × H28 × D10.1	Tough (Bending durability) FR-KZ50H	R2		STD 20 to 300 0.787 to 11.811 H-PWR 20 to 1,000 0.787 to 39.370	20 to 400 0.787 to 15.748 20 to 200 0.787 to 7.874 20 to 200 0.787 to 7.874	IP30	-40 to +60 °C	
	Side sensing  W9.5 × H25 × D5.2 W28 × H10.6 × D10.1	Tough (Bending durability) FR-KZ50E							

Notes: 1) Note that the sensing range of the free-cut type fiber may be reduced by 20 % max. depending upon how the fiber is cut.
 2) The sensing range is the possible setting range for the attached reflector. The fiber can detect an object less than setting range for the reflector.

<Sensing range when FR-Z50HW is used in combination with a reflector (optional)>

Reflector model No.	Sensing range (mm in)				
	FX-250 series				
	H-PWR	LONG	STD	FAST	H-SPD
RF-230	100 to 19,000 3.937 to 748.030	100 to 5,000 3.937 to 196.850	100 to 3,600 3.937 to 141.732	100 to 2,900 3.937 to 114.173	100 to 1,400 3.937 to 55.118
RF-220	100 to 8,000 3.937 to 314.960	100 to 3,500 3.937 to 137.795	100 to 3,000 3.937 to 118.110	100 to 1,800 3.937 to 70.866	100 to 830 3.937 to 32.677
RF-210	100 to 5,500 3.937 to 216.535	100 to 2,400 3.937 to 94.488	100 to 1,500 3.937 to 59.055	100 to 1,200 3.937 to 47.244	100 to 530 3.937 to 20.866

Note: The sensing range is the possible setting range for the reflector. The fiber can detect an object less than 100 mm 3.937 in. However, note that if there are any white or highly-reflective surfaces near the fiber head, reflected incident light may affect the fiber head. If this occurs, adjust the threshold value of the amplifier unit before use.

Tough : Refer to a fiber which possesses both unbreakable (bending radius: R10 mm **R0.394 in**, reciprocating bending: 180°) and more flexible (bending radius: R4 mm **R0.157 in** or less) features.
Bending durability : Refer to a fiber which possesses unbreakable bending-resistant feature (bending radius: R10 mm **R0.394 in**, reciprocating bending: 180°).

LIST OF FIBERS

<Heat-resistant joint fiber set contents>

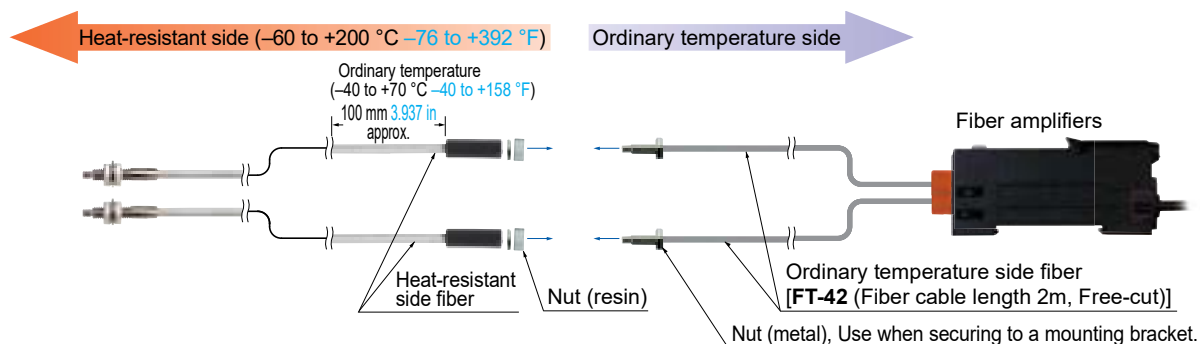

Heat-resistant

*Thru-beam type sensors are available as two pieces per set.

Type	Heat-resistant temp.	Shape of fiber head (mm)	Model No.	Bending radius (mm)	Fiber cable length ☒ : Free-cut	Sensing range (mm in) (Note 1)			Beam axis dia. (mm)	Ambient temp.
						FX-250 series		Other modes		
Thru-beam	350 °C	Lens mountable (FX-LE1/LE2/SV1) 	FT-H35-M2	R25	2 m	STD 430 16.929	670 26.378 250 9.843 80 3.150	ø1.2	-60 to +350 °C	
		Sleeve 60 mm 	FT-H35-M2S6	Fiber R25 Sleeve R10		H-PWR 1,200 47.244				
	200 °C	Allows flexible wiring Lens mountable (FX-LE1/LE2/SV1) 	FT-H20W-M1	R10	1 m	STD 470 18.504	840 33.071 300 11.811 90 3.543 (Note2)	ø0.8	-60 to +200 °C	
		Lens mountable (FX-LE1/LE2/SV1) 	FT-H20-M1	R25		STD 540 21.260				960 37.795 330 12.992 110 4.331 (Note2)
	130 °C	Lens mountable (FX-LE2 only) 	FT-H13-FM2	R25	☒ 2 m	STD 700 27.559	1,300 51.181 410 16.142 140 5.512	ø1.5	-60 to +130 °C	
Heat-resistant (joint)	200 °C	Lens mountable (FX-LE1/LE2/SV1) 	FT-H20-J20-S (Note 5)	Heat-resistant side R18 (Note 4)	☒ 200 mm (Note 3)	STD 470 18.504	790 31.102 300 11.811 90 3.543	ø1.2	-60 to +200 °C	
		Lens mountable (FX-LE1/LE2/SV1) 	FT-H20-J30-S (Note 5)		☒ 300 mm (Note 3)					H-PWR 1,600 62.992
		Lens mountable (FX-LE1/LE2/SV1) 	FT-H20-J50-S (Note 5)		☒ 500 mm (Note 3)	STD 600 23.622	980 38.583 390 15.354 120 4.724			
		Side-view 	FT-H20-VJ50-S (Note 5)		☒ 800 mm (Note 3)			H-PWR 2,100 82.677		
		Side-view 	FT-H20-VJ80-S (Note 5)		☒ 800 mm (Note 3)			H-PWR 2,100 82.677		

- Notes: 1) Note that the sensing range of the free-cut type fiber may be reduced by 20 % max. depending upon how the fiber is cut.
 2) The fiber cable length practically limits the sensing range.
 3) Fiber length (fixed-length) for heat-resistant fiber side. Fiber length for ordinary temperature side is 2 m 6.562 ft (free-cut).
 4) Bending-resistant fiber R4 mm **R0.157 in** or more for ordinary temperature side.
 5) Heat-resistant joint fibers and ordinary-temperature fibers (FT-42) are sold as a set.

Tough : Refer to a fiber which possesses both unbreakable (bending radius: R10 mm R0.394 in, reciprocating bending: 180°) and more flexible (bending radius: R4 mm R0.157 in or less) features.
Bending durability : Refer to a fiber which possesses unbreakable bending-resistant feature (bending radius: R10 mm R0.394 in, reciprocating bending: 180°).

LIST OF FIBERS

Heat-resistant

Type	Heat-resistant temp.	Shape of fiber head (mm)	Model No.	Bending radius (mm)	Fiber cable length Free-cut	Sensing range (mm in) (Note 1, 2)			Ambient temp.		
						FX-250 series	Other modes	LONG FAST H-SPD			
Reflective Heat-resistant	350 °C	Coaxial M6 25	FD-H35-M2	R25	2 m	STD 260 10.236		460 18.110	-60 to +350 °C		
		Sleeve 60 mm M6 22 ø2.8	FD-H35-M2S6	Fiber R25 Sleeve R10		H-PWR 720 28.346		150 5.906 45 1.772			
		Sleeve 90 mm M4 27 ø2.1	FD-H35-20S			STD 260 10.236		440 17.323 140 5.512 45 1.772			
	200 °C	Coaxial M6 28	FD-H20-M1		1 m	STD 330 12.992		500 19.685 200 7.874 55 2.165			
		Coaxial M4 27	FD-H20-21			STD 230 9.055		380 14.961 130 5.118 45 1.772			
	130 °C	M6 21	FD-H13-FM2		2 m	STD 350 13.780		600 23.622 200 7.874 65 2.559		-60 to +130 °C	
	Glass substrate detection convergent reflective	300 °C	W19 × H27 × D5	FD-H30-L32	R25	2 m	STD 0 to 17 0 to 0.669	0 to 25 0 to 0.984 0 to 12 0 to 0.472		1.5 to 6 0.059 to 0.236	-60 to +300 °C
		250 °C	W21 × H33.2 × D5	FD-H25-L43		3 m	STD 1.5 to 26 0.059 to 1.024	1 to 28 0.039 to 1.102 1.5 to 24 0.059 to 0.945		2 to 18 0.079 to 0.709	-20 to +250 °C (Ordinary temp. side: -20 to +70 °C)
			W21 × H34.5 × D5	FD-H25-L45			STD 5 to 42 0.197 to 1.654	4.5 to 43 0.177 to 1.693 5 to 40 0.197 to 1.575		6.5 to 34 0.256 to 1.339	
		180 °C	W19 × H27 × D5	FD-H18-L31		2 m	STD 0 to 16 0 to 0.630	0 to 24 0 to 0.945 0 to 13 0 to 0.512		2 to 6.5 0.079 to 0.256	

Notes: 1) Note that the sensing range of the free-cut type fiber may be reduced by 20 % max. depending upon how the fiber is cut.
 2) The sensing range of reflective type is the value for white non-glossy paper (50 × 50 mm 1.969 × 1.969 in glass substrate for FD-H30-L32 and FD-H18-L31, transparent glass 100 × 100 × 10.7 mm 3.937 × 3.937 × 10.028 in for FD-H25-L43 and FD-H25-L45).

Tough : Refer to a fiber which possesses both unbreakable (bending radius: R10 mm **R0.394 in**, reciprocating bending: 180°) and more flexible (bending radius: R4 mm **R0.157 in** or less) features.
Bending durability : Refer to a fiber which possesses unbreakable bending-resistant feature (bending radius: R10 mm **R0.394 in**, reciprocating bending: 180°).

LIST OF FIBERS

<One-touch connection system compatible with 4CH / 1CH flange Vacuum-resistant fiber set contents>

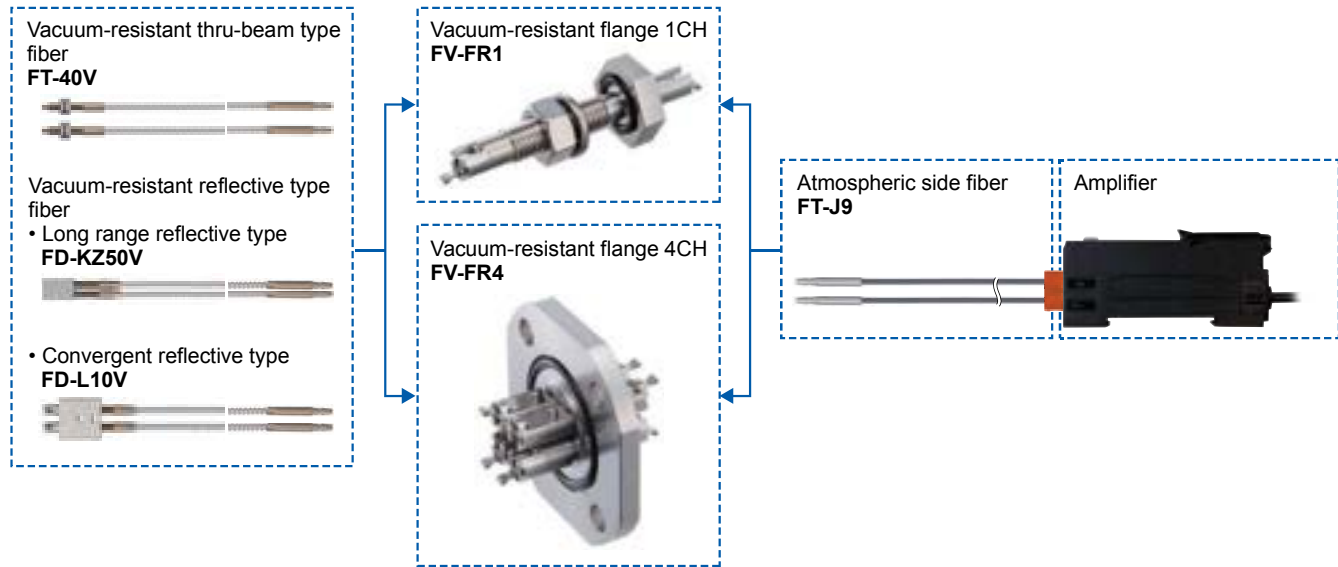

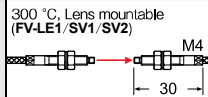
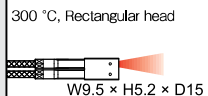
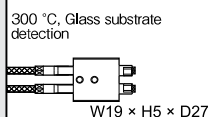

Vacuum-resistant (One-touch connection system compatible with 4CH / 1CH flange)

*Thru-beam type sensors are available as two pieces per set.

Type	Shape of fiber head (mm)	Model No.	Bending radius (mm)	Fiber cable length	Sensing range (mm in) (Note 3)			Beam axis dia. (mm)	Ambient temp.
					FX-250 series	Other modes	LONG FAST H-SPD		
Thru-beam Vacuum-resistant	300 °C, Lens mountable (FV-LE1, SV1, SV2) 	FT-40V	R25	1 m (Note 2)	STD 270 10.630	470 160 55	18.504 6.299 2.165	ø1.3	-30 to +300 °C
	H-PWR 1,000 39.370								
Long range reflective Vacuum-resistant	300 °C, Rectangular head 	FD-KZ50V	R25	1 m (Note 2)	STD 20 to 200 0.787 to 7.874		15 to 270 0.591 to 10.630 20 to 120 0.787 to 4.724 20 to 45 0.787 to 1.772	—	-30 to +300 °C
	H-PWR 5 to 500 0.197 to 19.685								
Convergent reflective Vacuum-resistant	300 °C, Glass substrate detection 	FD-L10V	R25	3 m (Note 2)	STD 0 to 8 0 to 0.315 H-PWR 0 to 18 0 to 0.709		0 to 10 0 to 0.394 0 to 5.5 0 to 0.217 1.5 to 3 0.059 to 0.118	—	-30 to +300 °C

- Notes: 1) Atmospheric side fiber is optional and sold separately.
 2) This is not a "free-cut" type. We offer only semi-custom products in which the fiber length can be specified in 100 mm **3.937 in** increments. For details, please contact our sales office.
 3) The sensing range is the value for transparent glass 100 × 100 × t0.7 mm **3.937 × 3.937 × t0.028 in**.
 4) Please refer to p.32 for lenses that can be installed on the **FT-40V**.

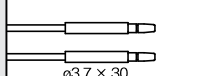
Atmospheric side (one pair set)



Type	Shape of fiber head (mm)	Model No.	Bending radius (mm)	Fiber cable length  : Free-cut	Ambient temp.
Atmospheric side	 ø3.7 × 30	Tough Bending durability FT-J9	R4	 2 m (Note 1, 2)	-30 to +80 °C

- Notes: 1) We offer only semi-custom products in which the fiber length can be specified in 1 m **3.280 ft** increments. For details, please contact our sales office.
 2) Note that the sensing range of the free-cut type fiber may be reduced by 20 % max. depending upon how the fiber is cut.

Tough : Refer to a fiber which possesses both unbreakable (bending radius: R10 mm **R0.394 in**, reciprocating bending: 180°) and more flexible (bending radius: R4 mm **R0.157 in** or less) features.
Bending durability : Refer to a fiber which possesses unbreakable bending-resistant feature (bending radius: R10 mm **R0.394 in**, reciprocating bending: 180°).

LIST OF FIBERS

Vacuum-resistant flange

Designation	Model No.	Description																															
Vacuum-resistant flange 1CH	FV-FR1		Atmospheric side and vacuum side are isolated.																														
			Main specifications																														
Vacuum-resistant flange 4CH	FV-FR4		<table border="1"> <thead> <tr> <th>Model No.</th> <th>FV-FR1</th> <th>FV-FR4</th> </tr> </thead> <tbody> <tr> <td>Applicable fibers</td> <td colspan="2">FT-40V, FD-KZ50V, FD-L10V, FT-J9</td> </tr> <tr> <td>Leakage</td> <td colspan="2">1.0 × 10⁻¹⁰ Pa·m³/s [He] or less (* Measured with a He detector)</td> </tr> <tr> <td>Ambient temperature</td> <td colspan="2">-30 to +120°C -22 to +248°F (Same for storage. Up to +40 °C +104°F when humidity is high. However, no dew condensation or icing allowed.)</td> </tr> <tr> <td>Ambient humidity</td> <td colspan="2">35 to 85% RH (Same for storage)</td> </tr> <tr> <td>Tightening torque</td> <td>Nut: 14.7 N·m or less (M14 nut)</td> <td>9.8 N·m or less (M8 screw)</td> </tr> <tr> <td>Tensile strength</td> <td colspan="2">20 N or less (Atmospheric / vacuum side fiber joint)</td> </tr> <tr> <td>O-ring size</td> <td>V15</td> <td>V40</td> </tr> <tr> <td>Weight</td> <td>100 g approx.</td> <td>410 g approx.</td> </tr> <tr> <td>Material</td> <td colspan="2">Main unit: Stainless steel (SUS303), Holding bracket: Stainless steel (SUS301), Fiber: Quartz glass, O-ring: Fluororubber</td> </tr> </tbody> </table>	Model No.	FV-FR1	FV-FR4	Applicable fibers	FT-40V, FD-KZ50V, FD-L10V, FT-J9		Leakage	1.0 × 10 ⁻¹⁰ Pa·m ³ /s [He] or less (* Measured with a He detector)		Ambient temperature	-30 to +120°C -22 to +248°F (Same for storage. Up to +40 °C +104°F when humidity is high. However, no dew condensation or icing allowed.)		Ambient humidity	35 to 85% RH (Same for storage)		Tightening torque	Nut: 14.7 N·m or less (M14 nut)	9.8 N·m or less (M8 screw)	Tensile strength	20 N or less (Atmospheric / vacuum side fiber joint)		O-ring size	V15	V40	Weight	100 g approx.	410 g approx.	Material	Main unit: Stainless steel (SUS303), Holding bracket: Stainless steel (SUS301), Fiber: Quartz glass, O-ring: Fluororubber	
			Model No.	FV-FR1	FV-FR4																												
			Applicable fibers	FT-40V, FD-KZ50V, FD-L10V, FT-J9																													
			Leakage	1.0 × 10 ⁻¹⁰ Pa·m ³ /s [He] or less (* Measured with a He detector)																													
			Ambient temperature	-30 to +120°C -22 to +248°F (Same for storage. Up to +40 °C +104°F when humidity is high. However, no dew condensation or icing allowed.)																													
			Ambient humidity	35 to 85% RH (Same for storage)																													
			Tightening torque	Nut: 14.7 N·m or less (M14 nut)	9.8 N·m or less (M8 screw)																												
			Tensile strength	20 N or less (Atmospheric / vacuum side fiber joint)																													
			O-ring size	V15	V40																												
			Weight	100 g approx.	410 g approx.																												
Material	Main unit: Stainless steel (SUS303), Holding bracket: Stainless steel (SUS301), Fiber: Quartz glass, O-ring: Fluororubber																																
			Recommended thickness of vacuum chamber wall																														
			• For FV-FR1 : 3.0 to 40.0 mm 0.118 to 1.575 in (Note 1)																														
			• For FV-FR4 : 3.0 mm 0.118 in or more (Note 2)																														

Notes: 1) Confirm the wall thickness in advance since the **FV-FR1** cannot be installed to a vacuum chamber with a wall thickness outside the recommended thickness range.
 2) If the vacuum chamber wall is too thick, the **FV-FR4** may not be able to connect to the vacuum side fiber. In that case, connect the **FV-FR4** to the vacuum side fiber before the installation.

<Vacuum-resistant fiber set contents>

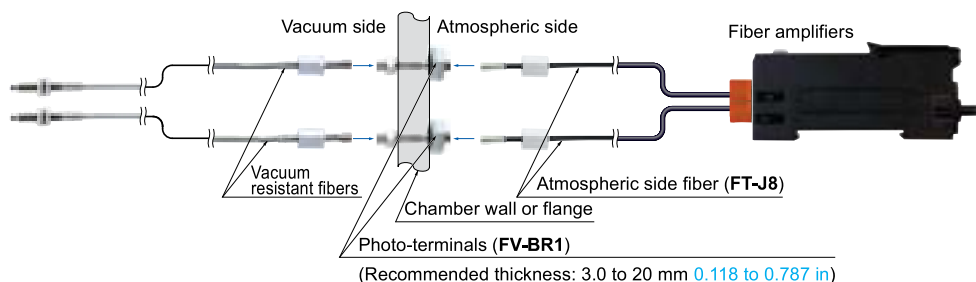

Vacuum-resistant

*Thru-beam type sensors are available as two pieces per set.

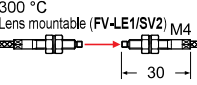
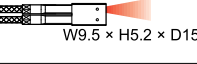
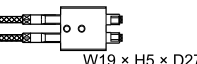
Type	Shape of fiber head (mm)	Model No.	Bending radius (mm)	Fiber cable length	Sensing range (mm in) (Note 3)		Beam axis dia. (mm)	Ambient temp.
					FX-250 series	Other modes LONG FAST H-SPD		
Thru-beam	300 °C Lens mountable (FV-LE1/SV2) M4 	FT-H30-M1V-S (Note 1)	R18	1 m (Note 2)	STD	470 18.504	ø1.2	-30 to +300 °C
					H-PWR	160 6.299 55 2.165		
Reflective	300 °C, Rectangular head 	FD-H30-KZ1V-S (Note 1)	R18	1 m (Note 2)	STD	15 to 270 0.591 to 10.630	-	-30 to +300 °C
					H-PWR	20 to 120 0.787 to 4.724 20 to 45 0.787 to 1.772 5 to 500 0.197 to 19.685		
Convergent reflective	300 °C, Glass substrate detection 	FD-H30-L32V-S (Note 1)		3 m (Note 2)	STD	0 to 10 0 to 0.394 0 to 5.5 0 to 0.217 1.5 to 3 0.059 to 0.118		

Notes: 1) Sold as a set comprising vacuum type fiber + photo-terminal (**FV-BR1**) + fiber at atmospheric side (**FT-J8**).
 2) This is not a "free-cut" type.
 3) The sensing range is the value for transparent glass 100 × 100 × 10.7 mm **3.937 × 3.937 × 10.028 in**.

Tough : Refer to a fiber which possesses both unbreakable (bending radius: R10 mm **R0.394 in**, reciprocating bending: 180°) and more flexible (bending radius: R4 mm **R0.157 in** or less) features.
Bending durability : Refer to a fiber which possesses unbreakable bending-resistant feature (bending radius: R10 mm **R0.394 in**, reciprocating bending: 180°).

LIST OF FIBERS

Oil-resistant

*Thru-beam type sensors are available as two pieces per set.

Type		Shape of fiber head (mm)	Model No.	Bending radius (mm)	Fiber cable length Free-cut	Sensing range (mm in) (Note 1, 2)			Beam axis dia. (mm)	Protection	Ambient temp.
						FX-250 series		Other modes			
Thru-beam Oil-resistant	Square head type	<p>Full-protection type W10 × H11 × D21.2</p>	Tough (Bending durability) FT-R60Y	R4	2 m	STD 2,100 82.677 H-PWR (Note 3) 3,600 141.732	3,600 141.732 (Note 3) 1,260 49.606 400 15.748	ø3.5	IP68G	-55 to +80 °C	
						STD 720 28.346 H-PWR 3,000 118.110					1,100 43.307 430 16.929 130 5.118
Reflective Oil-resistant	Square head type	<p>Cable-protection type Lens mountable W7 × H9.5 × D15.5</p>	Tough (Bending durability) FT-R44Y	R4	2 m	STD 280 11.024 H-PWR 990 38.976	435 17.126 160 6.299 50 1.969	—	IP67 (Note 4)	-55 to +80 °C	

- Notes: 1) Note that the sensing range of the free-cut type fiber may be reduced by 20 % max. depending upon how the fiber is cut.
 2) The sensing range of reflective type is specified for white non-glossy paper.
 3) The fiber cable length practically limits the sensing range.
 4) The fiber part is oil-resistant.

Chemical-resistant

*Thru-beam type sensors are available as two pieces per set.











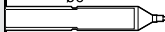

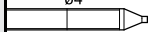

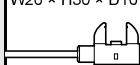
Type		Shape of fiber head (mm)	Model No.	Bending radius (mm)	Fiber cable length Free-cut	Sensing range (mm in) (Note 1, 2)			Beam axis dia. (mm)	Protection	Ambient temp.
						FX-250 series		Other modes			
Thru-beam Chemical-resistant	Flat type	<p>Easy mounting • Rectangular head SEMI S2 compliant (Note 5) Metal-free W7 × H15 × D13</p>	Tough (Bending durability) FT-Z802Y	R4	2 m	STD 3,100 122.047 H-PWR (Note 3) 3,600 141.732	3,600 141.732 (Note 3) 1,900 74.803 470 18.504	ø3.7	IP68G	0 to +60 °C	
						STD (Note 3) 3,600 141.732 H-PWR (Note 3) 3,600 141.732				3,600 141.732 (Note 3) 2,300 90.551 740 29.134	-40 to +115 °C
	Cylindrical type	<p>Heat-resistant 115 °C Metal-free ø5.5 (25)</p>	FT-HL80Y (Note 6)	R30	2 m (Note 4)	STD (Note 3) 3,600 141.732 H-PWR (Note 3) 3,600 141.732	3,600 141.732 (Note 3) 2,800 110.236 920 36.220	ø2.8	IP68G	-40 to +70 °C	
						STD (Note 3) 3,600 141.732 H-PWR (Note 3) 3,600 141.732				3,600 141.732 (Note 3) 2,800 110.236 920 36.220	-40 to +70 °C
Side-view Metal-free	<p>ø5.5 (25)</p>	FT-V80Y	STD 1,300 51.181 H-PWR (Note 3) 3,600 141.732	2,200 86.614 800 31.496 240 9.449							
Reflective Chemical-resistant	Cylindrical type	<p>Metal-free ø5.5 (16)</p>	Tough (Bending durability) FD-S60Y	R4	2 m (Note 4)	STD 320 12.598 H-PWR 600 23.622	420 16.535 200 7.874 75 2.953	—	IP68G	-40 to +70 °C	

- Notes: 1) Note that the sensing range of the free-cut type fiber may be reduced by 20 % max. depending upon how the fiber is cut.
 2) The sensing range of reflective type is specified for white non-glossy paper.
 3) The fiber cable length practically limits the sensing range.
 4) The allowable cutting range is 500 mm **19.685 in** from the end that the amplifier inserted.
 5) The design takes into account the environmental testing required by SEMI S2. To ensure that the final system complies with the standards, you must design and use it in accordance with relevant standards, laws, and regulations.
 6) The **FT-HL80Y** will be discontinued at the end of September 2025.

Tough : Refer to a fiber which possesses both unbreakable (bending radius: R10 mm [R0.394 in](#), reciprocating bending: 180°) and more flexible (bending radius: R4 mm [R0.157 in](#) or less) features.
 : Refer to a fiber which possesses unbreakable bending-resistant feature (bending radius: R10 mm [R0.394 in](#), reciprocating bending: 180°).

LIST OF FIBERS

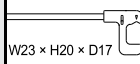
Liquid leak / Liquid detection

Type	Shape of fiber head (mm)	Model No.	Bending radius (mm)	Fiber cable length  : Free-cut	Description		Protection	Ambient temp.	
					FX-250 series (STD mode)				
Reflective type	Contact type	Liquid level sensing	Heat resistant 125 °C Fluorine resin coating ø6 	FD-F8Y	Protective tube R40 Fiber R15 	2 m (Note 1)	ø6 mm ø0.236 in Protective tube: Fluorine resin, length 1,000 mm 39.370 in (not cuttable) Liquid surface not contacted: Beam received, Liquid surface contacted: Beam not received	IP68	-40 to +125 °C
			Heat resistant 105 °C Fluorine resin coating Metal-free ø4 	FD-HF40Y (Note 2)	Protective tube R20 Fiber R10 	2 m	ø4 mm ø0.157 in Protective tube: Fluorine resin, length 500 mm 19.685 in (cuttable) Liquid surface not contacted: Beam received, Liquid surface contacted: Beam not received	IP68G	-40 to +105 °C
	Liquid leak detection	SEMI S2 compliant (Note 3) W20 × H30 × D10 	Tough  FD-F71	Protective tube R20 Fiber R2 	5 m	Liquid leak detection Leak absent: Beam received, Leak present: Beam not received	IP67	-20 to +60 °C	
Reflective type	Pipe-mountable type	Liquid level sensing	Standard  W25 × H13 × D20	FD-F41	R10		Applicable pipe diameter: Outer dia. ø6 to ø26 mm ø0.236 to ø1.024 in transparent pipe [PVC (vinyl chloride), fluorine resin, polycarbonate, acrylic, glass, wall thickness 1 to 3 mm 0.039 to 0.118 in] Liquid absent: Beam received, Liquid present: Beam not received	-	-40 to +100 °C
			For 1 mm thick PFA pipe  W25 × H13 × D20	FD-F4					
		Liquid sensing	Array fiber  W6.5 × H28.3 × D17	Tough  FD-FA93	R4	2 m	Applicable pipe diameter: Outer dia. ø8 mm ø0.315 in or more transparent pipe (When used with the tying bands: ø8 to ø80 mm ø0.315 to ø3.150 in) [PFA (fluorine resin), including translucent] Liquid absent: Beam received, Liquid present: Beam not received	IP40	-40 to +70 °C
Thru-beam type	Liquid sensing	SEMI S2 compliant (Note 3)  W23 × H20 × D17	Tough  FT-F93	Protective tube R20 Fiber R2 	Applicable pipe diameter: Outer dia. ø3 to ø10 mm ø0.118 to ø0.394 in transparent pipe [PFA (fluorine resin) or equivalently transparent pipe, wall thickness 0.3 to 1 mm 0.012 to 0.039 in] Liquid absent: Beam not received, Liquid present: Beam received	-40 to +60 °C			

- Notes: 1) The allowable cutting range is 1,000 mm [39.370 in](#) from the end that the amplifier inserted.
 2) Liquid inflow prevention joint, protective tube extension joint, fiber mounting joint is available.
 3) The design takes into account the environmental testing required by SEMI S2. To ensure that the final system complies with the standards, you must design and use it in accordance with relevant standards, laws, and regulations.

FIBER OPTIONS

Lens (For thru-beam type fiber)

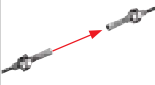
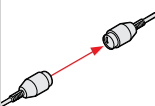
Designation	Model No.	Description																																																																											
For thru-beam type fiber	Expansion lens (Note 1)	<p>FX-LE1</p>  <p>Increases the sensing range by 5 times or more. • Ambient temperature: -60 to +350 °C -76 to +662 °F (Note 3) • Beam dia: ø3.6 mm ø0.142 in</p> <p>Sensing range (mm in) [Lens on both sides]</p> <table border="1"> <thead> <tr> <th rowspan="2">Fiber</th> <th rowspan="2">Amplifier Mode</th> <th colspan="5">FX-250 series</th> </tr> <tr> <th>H-PWR</th> <th>LONG</th> <th>STD</th> <th>FAST</th> <th>H-SPD</th> </tr> </thead> <tbody> <tr> <td>FT-43</td> <td></td> <td>3,600 141.732 (Note 2)</td> <td>3,600 141.732 (Note 2)</td> <td>3,600 141.732 (Note 2)</td> <td>3,600 141.732 (Note 2)</td> <td>1,600 62.992</td> </tr> <tr> <td>FT-42 FT-42W</td> <td></td> <td>3,600 141.732 (Note 2)</td> <td>3,600 141.732 (Note 2)</td> <td>3,600 141.732 (Note 2)</td> <td>3,600 141.732 (Note 2)</td> <td>2,200 86.614</td> </tr> <tr> <td>FT-45X</td> <td></td> <td>1,600 62.992 (Note 2)</td> <td>1,600 62.992 (Note 2)</td> <td>1,600 62.992 (Note 2)</td> <td>1,600 62.992 (Note 2)</td> <td>1,500 59.055</td> </tr> <tr> <td>FT-R40</td> <td></td> <td>3,600 141.732 (Note 2)</td> <td>3,600 141.732 (Note 2)</td> <td>3,600 141.732 (Note 2)</td> <td>3,600 141.732 (Note 2)</td> <td>1,900 74.803</td> </tr> <tr> <td>FT-R43 FT-R44Y</td> <td></td> <td>3,600 141.732 (Note 2)</td> <td>3,600 141.732 (Note 2)</td> <td>3,600 141.732 (Note 2)</td> <td>1,900 74.803</td> <td>670 26.376</td> </tr> <tr> <td>FT-H35-M2</td> <td></td> <td>3,600 141.732 (Note 2)</td> <td>3,600 141.732 (Note 2)</td> <td>3,600 141.732 (Note 2)</td> <td>3,300 129.921</td> <td>1,400 55.118</td> </tr> <tr> <td>FT-H20W-M1</td> <td></td> <td>1,600 62.992 (Note 2)</td> <td>1,600 62.992 (Note 2)</td> <td>1,600 62.992 (Note 2)</td> <td>1,600 62.992 (Note 2)</td> <td>850 33.465</td> </tr> <tr> <td>FT-H20-M1</td> <td></td> <td>1,600 62.992 (Note 2)</td> <td>1,600 62.992 (Note 2)</td> <td>1,600 62.992 (Note 2)</td> <td>1,600 62.992 (Note 2)</td> <td>1,200 47.244</td> </tr> <tr> <td>FT-H20-J50-S FT-H20-J30-S FT-H20-J20-S</td> <td></td> <td>3,600 141.732 (Note 2)</td> <td>3,500 137.795</td> <td>2,000 78.740</td> <td>1,600 62.992</td> <td>500 19.685</td> </tr> </tbody> </table>	Fiber	Amplifier Mode	FX-250 series					H-PWR	LONG	STD	FAST	H-SPD	FT-43		3,600 141.732 (Note 2)	3,600 141.732 (Note 2)	3,600 141.732 (Note 2)	3,600 141.732 (Note 2)	1,600 62.992	FT-42 FT-42W		3,600 141.732 (Note 2)	3,600 141.732 (Note 2)	3,600 141.732 (Note 2)	3,600 141.732 (Note 2)	2,200 86.614	FT-45X		1,600 62.992 (Note 2)	1,600 62.992 (Note 2)	1,600 62.992 (Note 2)	1,600 62.992 (Note 2)	1,500 59.055	FT-R40		3,600 141.732 (Note 2)	3,600 141.732 (Note 2)	3,600 141.732 (Note 2)	3,600 141.732 (Note 2)	1,900 74.803	FT-R43 FT-R44Y		3,600 141.732 (Note 2)	3,600 141.732 (Note 2)	3,600 141.732 (Note 2)	1,900 74.803	670 26.376	FT-H35-M2		3,600 141.732 (Note 2)	3,600 141.732 (Note 2)	3,600 141.732 (Note 2)	3,300 129.921	1,400 55.118	FT-H20W-M1		1,600 62.992 (Note 2)	1,600 62.992 (Note 2)	1,600 62.992 (Note 2)	1,600 62.992 (Note 2)	850 33.465	FT-H20-M1		1,600 62.992 (Note 2)	1,600 62.992 (Note 2)	1,600 62.992 (Note 2)	1,600 62.992 (Note 2)	1,200 47.244	FT-H20-J50-S FT-H20-J30-S FT-H20-J20-S		3,600 141.732 (Note 2)	3,500 137.795	2,000 78.740	1,600 62.992	500 19.685
	Fiber	Amplifier Mode			FX-250 series																																																																								
H-PWR			LONG	STD	FAST	H-SPD																																																																							
FT-43		3,600 141.732 (Note 2)	3,600 141.732 (Note 2)	3,600 141.732 (Note 2)	3,600 141.732 (Note 2)	1,600 62.992																																																																							
FT-42 FT-42W		3,600 141.732 (Note 2)	3,600 141.732 (Note 2)	3,600 141.732 (Note 2)	3,600 141.732 (Note 2)	2,200 86.614																																																																							
FT-45X		1,600 62.992 (Note 2)	1,600 62.992 (Note 2)	1,600 62.992 (Note 2)	1,600 62.992 (Note 2)	1,500 59.055																																																																							
FT-R40		3,600 141.732 (Note 2)	3,600 141.732 (Note 2)	3,600 141.732 (Note 2)	3,600 141.732 (Note 2)	1,900 74.803																																																																							
FT-R43 FT-R44Y		3,600 141.732 (Note 2)	3,600 141.732 (Note 2)	3,600 141.732 (Note 2)	1,900 74.803	670 26.376																																																																							
FT-H35-M2		3,600 141.732 (Note 2)	3,600 141.732 (Note 2)	3,600 141.732 (Note 2)	3,300 129.921	1,400 55.118																																																																							
FT-H20W-M1		1,600 62.992 (Note 2)	1,600 62.992 (Note 2)	1,600 62.992 (Note 2)	1,600 62.992 (Note 2)	850 33.465																																																																							
FT-H20-M1		1,600 62.992 (Note 2)	1,600 62.992 (Note 2)	1,600 62.992 (Note 2)	1,600 62.992 (Note 2)	1,200 47.244																																																																							
FT-H20-J50-S FT-H20-J30-S FT-H20-J20-S		3,600 141.732 (Note 2)	3,500 137.795	2,000 78.740	1,600 62.992	500 19.685																																																																							
	Super-expansion lens (Note 1)	<p>FX-LE2</p>  <p>Tremendously increases the sensing range with large diameter lenses. • Ambient temperature: -60 to +350 °C -76 to +662 °F (Note 3) • Beam dia: ø9.8 mm ø0.386 in</p> <p>Sensing range (mm in) [Lens on both sides]</p> <table border="1"> <thead> <tr> <th rowspan="2">Fiber</th> <th rowspan="2">Amplifier Mode</th> <th colspan="5">FX-250 series</th> </tr> <tr> <th>H-PWR</th> <th>LONG</th> <th>STD</th> <th>FAST</th> <th>H-SPD</th> </tr> </thead> <tbody> <tr> <td>FT-43 FT-42 FT-42W</td> <td></td> <td>3,600 141.732 (Note 2)</td> <td>3,600 141.732 (Note 2)</td> <td>3,600 141.732 (Note 2)</td> <td>3,600 141.732 (Note 2)</td> <td>3,600 141.732 (Note 2)</td> </tr> <tr> <td>FT-45X</td> <td></td> <td>1,600 62.992 (Note 2)</td> <td>1,600 62.992 (Note 2)</td> <td>1,600 62.992 (Note 2)</td> <td>1,600 62.992 (Note 2)</td> <td>1,600 62.992 (Note 2)</td> </tr> <tr> <td>FT-R40</td> <td></td> <td>3,600 141.732 (Note 2)</td> <td>3,600 141.732 (Note 2)</td> <td>3,600 141.732 (Note 2)</td> <td>3,600 141.732 (Note 2)</td> <td>3,600 141.732 (Note 2)</td> </tr> <tr> <td>FT-R41W FT-R43 FT-R44Y</td> <td></td> <td>3,600 141.732 (Note 2)</td> <td>3,600 141.732 (Note 2)</td> <td>3,600 141.732 (Note 2)</td> <td>3,600 141.732 (Note 2)</td> <td>3,600 141.732 (Note 2)</td> </tr> <tr> <td>FT-H35-M2</td> <td></td> <td>3,600 141.732 (Note 2)</td> <td>3,600 141.732 (Note 2)</td> <td>3,600 141.732 (Note 2)</td> <td>3,600 141.732 (Note 2)</td> <td>3,600 141.732 (Note 2)</td> </tr> <tr> <td>FT-H20W-M1 FT-H20-M1</td> <td></td> <td>1,600 62.992 (Note 2)</td> <td>1,600 62.992 (Note 2)</td> <td>1,600 62.992 (Note 2)</td> <td>1,600 62.992 (Note 2)</td> <td>1,600 62.992 (Note 2)</td> </tr> <tr> <td>FT-H13-FM2</td> <td></td> <td>3,600 141.732 (Note 2)</td> <td>3,600 141.732 (Note 2)</td> <td>3,600 141.732 (Note 2)</td> <td>3,600 141.732 (Note 2)</td> <td>3,600 141.732 (Note 2)</td> </tr> <tr> <td>FT-H20-J50-S FT-H20-J30-S FT-H20-J20-S</td> <td></td> <td>3,600 141.732 (Note 2)</td> <td>3,600 141.732 (Note 2)</td> <td>3,600 141.732 (Note 2)</td> <td>3,600 141.732 (Note 2)</td> <td>3,600 141.732 (Note 2)</td> </tr> </tbody> </table>	Fiber	Amplifier Mode	FX-250 series					H-PWR	LONG	STD	FAST	H-SPD	FT-43 FT-42 FT-42W		3,600 141.732 (Note 2)	3,600 141.732 (Note 2)	3,600 141.732 (Note 2)	3,600 141.732 (Note 2)	3,600 141.732 (Note 2)	FT-45X		1,600 62.992 (Note 2)	1,600 62.992 (Note 2)	1,600 62.992 (Note 2)	1,600 62.992 (Note 2)	1,600 62.992 (Note 2)	FT-R40		3,600 141.732 (Note 2)	3,600 141.732 (Note 2)	3,600 141.732 (Note 2)	3,600 141.732 (Note 2)	3,600 141.732 (Note 2)	FT-R41W FT-R43 FT-R44Y		3,600 141.732 (Note 2)	3,600 141.732 (Note 2)	3,600 141.732 (Note 2)	3,600 141.732 (Note 2)	3,600 141.732 (Note 2)	FT-H35-M2		3,600 141.732 (Note 2)	3,600 141.732 (Note 2)	3,600 141.732 (Note 2)	3,600 141.732 (Note 2)	3,600 141.732 (Note 2)	FT-H20W-M1 FT-H20-M1		1,600 62.992 (Note 2)	1,600 62.992 (Note 2)	1,600 62.992 (Note 2)	1,600 62.992 (Note 2)	1,600 62.992 (Note 2)	FT-H13-FM2		3,600 141.732 (Note 2)	3,600 141.732 (Note 2)	3,600 141.732 (Note 2)	3,600 141.732 (Note 2)	3,600 141.732 (Note 2)	FT-H20-J50-S FT-H20-J30-S FT-H20-J20-S		3,600 141.732 (Note 2)	3,600 141.732 (Note 2)	3,600 141.732 (Note 2)	3,600 141.732 (Note 2)	3,600 141.732 (Note 2)							
Fiber	Amplifier Mode	FX-250 series																																																																											
		H-PWR	LONG	STD	FAST	H-SPD																																																																							
FT-43 FT-42 FT-42W		3,600 141.732 (Note 2)	3,600 141.732 (Note 2)	3,600 141.732 (Note 2)	3,600 141.732 (Note 2)	3,600 141.732 (Note 2)																																																																							
FT-45X		1,600 62.992 (Note 2)	1,600 62.992 (Note 2)	1,600 62.992 (Note 2)	1,600 62.992 (Note 2)	1,600 62.992 (Note 2)																																																																							
FT-R40		3,600 141.732 (Note 2)	3,600 141.732 (Note 2)	3,600 141.732 (Note 2)	3,600 141.732 (Note 2)	3,600 141.732 (Note 2)																																																																							
FT-R41W FT-R43 FT-R44Y		3,600 141.732 (Note 2)	3,600 141.732 (Note 2)	3,600 141.732 (Note 2)	3,600 141.732 (Note 2)	3,600 141.732 (Note 2)																																																																							
FT-H35-M2		3,600 141.732 (Note 2)	3,600 141.732 (Note 2)	3,600 141.732 (Note 2)	3,600 141.732 (Note 2)	3,600 141.732 (Note 2)																																																																							
FT-H20W-M1 FT-H20-M1		1,600 62.992 (Note 2)	1,600 62.992 (Note 2)	1,600 62.992 (Note 2)	1,600 62.992 (Note 2)	1,600 62.992 (Note 2)																																																																							
FT-H13-FM2		3,600 141.732 (Note 2)	3,600 141.732 (Note 2)	3,600 141.732 (Note 2)	3,600 141.732 (Note 2)	3,600 141.732 (Note 2)																																																																							
FT-H20-J50-S FT-H20-J30-S FT-H20-J20-S		3,600 141.732 (Note 2)	3,600 141.732 (Note 2)	3,600 141.732 (Note 2)	3,600 141.732 (Note 2)	3,600 141.732 (Note 2)																																																																							

- Notes: 1) Be careful sure to use it only after you have adjusted it sufficiently when installing the thru-beam type fiber equipped with the expansion lens, as the beam envelope becomes narrow and alignment is difficult.
 2) The fiber cable length practically limits the sensing range.
 3) Refer to [LIST OF FIBERS](#) (p.10~) for the ambient temperature of fibers to be used in combination.

FIBER OPTIONS



Lens (For thru-beam type fiber)

Designation		Model No.	Description							
For thru-beam type fiber	Side-view lens	FX-SV1		Beam axis is bent by 90°. <ul style="list-style-type: none"> • Ambient temperature: -60 to +300 °C -76 to +572 °F (Note 1) • Beam dia: ø2.8 mm ø0.110 in Sensing range (mm in) [Lens on both sides]						
				Amplifier		FX-250 series				
				Fiber	Mode	H-PWR	LONG	STD	FAST	H-SPD
				FT-43		3,600 141.732 (Note 2)	2,600 102.362	1,700 66.929	970 38.189	310 12.205
				FT-42		3,600 141.732 (Note 2)	3,600 141.732 (Note 2)	2,100 82.677	1,150 45.276	370 14.567
				FT-42W		3,600 141.732 (Note 2)	2,700 106.299	1,800 70.866	990 38.976	320 12.598
				FT-45X		1,600 62.992 (Note 2)	1,600 62.992 (Note 2)	1,400 55.118	800 31.496	210 8.268
				FT-R43		3,200 125.984	1,300 51.181	950 37.402	510 20.079	160 6.299
				FT-R44Y		3,200 125.984	1,300 51.181	950 37.402	510 20.079	160 6.299
				FT-H35-M2		3,500 137.795	1,200 47.244	780 30.709	500 19.685	150 5.906
				FT-H20W-M1		1,600 62.992 (Note 2)	1,500 59.055	950 37.402	560 22.047	190 7.480
				FT-H20-M1		1,600 62.992 (Note 2)	1,300 51.181	780 30.709	500 19.685	150 5.906
				FT-H20-J50-S FT-H20-J30-S FT-H20-J20-S		1,600 62.992 (Note 2)	740 29.134	450 17.717	290 11.417	80 3.150

Notes: 1) Refer to [LIST OF FIBERS](#) (p.10~) for the ambient temperature of fibers to be used in combination.
 2) The fiber cable length practically limits the sensing range.

FIBER OPTIONS

Vacuum-resistant lens (For thru-beam type fiber)

Designation	Model No.	Description																																							
For thru-beam type fiber	Vacuum-resistant expansion lens (Note 1)	FV-LE1	 <p>Increases the sensing range 4 times or more. • Ambient temperature: -60 to +350 °C -76 to +662 °F (Note 5) • Beam axis dia: \varnothing3.6 mm \varnothing0.142 in Sensing range (mm in) [Lens on both sides] (Note 3, 4)</p> <table border="1"> <thead> <tr> <th rowspan="2">Fiber</th> <th rowspan="2">Mode</th> <th colspan="5">FX-250 series</th> </tr> <tr> <th>H-PWR</th> <th>LONG</th> <th>STD</th> <th>FAST</th> <th>H-SPD</th> </tr> </thead> <tbody> <tr> <td rowspan="2">FT-40V</td> <td></td> <td>1,800 (Note 2)</td> <td>1,800 (Note 2)</td> <td>1,500</td> <td>900</td> <td>370</td> </tr> <tr> <td></td> <td>70,866</td> <td>70,866</td> <td>59,055</td> <td>35,433</td> <td>14,567</td> </tr> <tr> <td rowspan="2">FT-H30-M1V-S</td> <td></td> <td>3,600 (Note 2)</td> <td>3,400</td> <td>1,500</td> <td>900</td> <td>370</td> </tr> <tr> <td></td> <td>141,732</td> <td>133,858</td> <td>59,055</td> <td>35,433</td> <td>14,567</td> </tr> </tbody> </table>	Fiber	Mode	FX-250 series					H-PWR	LONG	STD	FAST	H-SPD	FT-40V		1,800 (Note 2)	1,800 (Note 2)	1,500	900	370		70,866	70,866	59,055	35,433	14,567	FT-H30-M1V-S		3,600 (Note 2)	3,400	1,500	900	370		141,732	133,858	59,055	35,433	14,567
	Fiber	Mode	FX-250 series																																						
			H-PWR	LONG	STD	FAST	H-SPD																																		
FT-40V		1,800 (Note 2)	1,800 (Note 2)	1,500	900	370																																			
		70,866	70,866	59,055	35,433	14,567																																			
FT-H30-M1V-S		3,600 (Note 2)	3,400	1,500	900	370																																			
		141,732	133,858	59,055	35,433	14,567																																			
Vacuum-resistant compact side-view lens (Note 1)	FV-SV1	 <p>Beam axis is bent by 90°. • Ambient temperature: -30 to +300 °C -22 to +572 °F (Note 5) • Beam axis dia: \varnothing3 mm \varnothing0.118 in Sensing range (mm in) [Lens on both sides] (Note 3, 4)</p> <table border="1"> <thead> <tr> <th rowspan="2">Fiber</th> <th rowspan="2">Mode</th> <th colspan="5">FX-250 series</th> </tr> <tr> <th>H-PWR</th> <th>LONG</th> <th>STD</th> <th>FAST</th> <th>H-SPD</th> </tr> </thead> <tbody> <tr> <td rowspan="2">FT-40V</td> <td></td> <td>1,800 (Note 2)</td> <td>700</td> <td>450</td> <td>290</td> <td>90</td> </tr> <tr> <td></td> <td>70,866</td> <td>27,559</td> <td>17,717</td> <td>11,417</td> <td>3,543</td> </tr> <tr> <td rowspan="2">FT-H30-M1V-S</td> <td></td> <td>1,800</td> <td>700</td> <td>450</td> <td>290</td> <td>90</td> </tr> <tr> <td></td> <td>70,866</td> <td>27,559</td> <td>17,717</td> <td>11,417</td> <td>3,543</td> </tr> </tbody> </table>	Fiber	Mode	FX-250 series					H-PWR	LONG	STD	FAST	H-SPD	FT-40V		1,800 (Note 2)	700	450	290	90		70,866	27,559	17,717	11,417	3,543	FT-H30-M1V-S		1,800	700	450	290	90		70,866	27,559	17,717	11,417	3,543	
Fiber	Mode	FX-250 series																																							
		H-PWR	LONG	STD	FAST	H-SPD																																			
FT-40V		1,800 (Note 2)	700	450	290	90																																			
		70,866	27,559	17,717	11,417	3,543																																			
FT-H30-M1V-S		1,800	700	450	290	90																																			
		70,866	27,559	17,717	11,417	3,543																																			
Vacuum-resistant side-view lens (Note 1)	FV-SV2	 <p>Beam axis is bent by 90°. • Ambient temperature: -60 to +300 °C -76 to +572 °F (Note 5) • Beam axis dia: \varnothing3.7 mm \varnothing0.146 in Sensing range (mm in) [Lens on both sides] (Note 3, 4)</p> <table border="1"> <thead> <tr> <th rowspan="2">Fiber</th> <th rowspan="2">Mode</th> <th colspan="5">FX-250 series</th> </tr> <tr> <th>H-PWR</th> <th>LONG</th> <th>STD</th> <th>FAST</th> <th>H-SPD</th> </tr> </thead> <tbody> <tr> <td rowspan="2">FT-40V</td> <td></td> <td>1,800 (Note 2)</td> <td>1,800 (Note 2)</td> <td>1,500</td> <td>900</td> <td>370</td> </tr> <tr> <td></td> <td>70,866</td> <td>70,866</td> <td>59,055</td> <td>35,433</td> <td>14,567</td> </tr> <tr> <td rowspan="2">FT-H30-M1V-S</td> <td></td> <td>3,600</td> <td>3,400</td> <td>1,500</td> <td>900</td> <td>370</td> </tr> <tr> <td></td> <td>141,732 (Note 2)</td> <td>133,858</td> <td>59,055</td> <td>35,433</td> <td>14,567</td> </tr> </tbody> </table>	Fiber	Mode	FX-250 series					H-PWR	LONG	STD	FAST	H-SPD	FT-40V		1,800 (Note 2)	1,800 (Note 2)	1,500	900	370		70,866	70,866	59,055	35,433	14,567	FT-H30-M1V-S		3,600	3,400	1,500	900	370		141,732 (Note 2)	133,858	59,055	35,433	14,567	
Fiber	Mode	FX-250 series																																							
		H-PWR	LONG	STD	FAST	H-SPD																																			
FT-40V		1,800 (Note 2)	1,800 (Note 2)	1,500	900	370																																			
		70,866	70,866	59,055	35,433	14,567																																			
FT-H30-M1V-S		3,600	3,400	1,500	900	370																																			
		141,732 (Note 2)	133,858	59,055	35,433	14,567																																			

- Notes: 1) Be careful when installing the thru-beam type fiber equipped with the lens, as the beam envelope becomes narrow and alignment is difficult.
 2) The fiber cable length practically limits the sensing range.
 3) The fiber cable length for the **FT-40V** is 1 m **3.281 ft**. The sensing ranges take into account the length of the **FT-J9** atmospheric side fiber.
 4) The fiber cable length for the **FT-H30-M1V-S** is 1 m **3.281 ft**. The sensing ranges in H-PWR and LONG of **FX-250** series are specified considering the length of the **FT-J8** atmospheric side fiber.
 5) Refer to **LIST OF FIBERS** (p.10~) for the ambient temperature of fibers to be used in combination.

FIBER OPTIONS

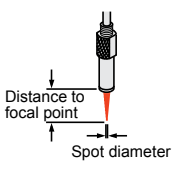
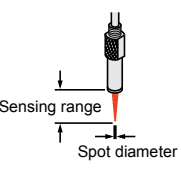

Lens (For reflective type fiber)

Designation	Model No.	Description																
For reflective type fiber	Finest spot lens	FX-MR7	<p>Extremely fine spot of $\varnothing 0.1$ mm $\varnothing 0.004$ in approx. achieved.</p> <ul style="list-style-type: none"> Applicable fibers: FD-R33EG, FD-EG31, FD-R34EG, FD-R32EG, FD-EG30, FD-R31G, FD-42G, FD-42GW, FD-32G, FD-32GX Ambient temperature: -55 to +70 °C $+67$ to $+158$ °F (Note) 	<p>Sensing range for FX-250 series</p> <table border="1"> <thead> <tr> <th>Fiber model No.</th> <th>Distance to focal point</th> <th>Spot diameter</th> </tr> </thead> <tbody> <tr> <td>FD-R33EG FD-EG31</td> <td rowspan="4">7 ±0.5 mm 0.276 ±0.020 in</td> <td>$\varnothing 0.1$ mm approx. $\varnothing 0.004$ in approx.</td> </tr> <tr> <td>FD-R34EG</td> <td>$\varnothing 0.15$ mm approx. $\varnothing 0.006$ in approx.</td> </tr> <tr> <td>FD-R32EG FD-EG30</td> <td>$\varnothing 0.2$ mm approx. $\varnothing 0.008$ in approx.</td> </tr> <tr> <td>FD-R31G FD-42G/42GW FD-32G/32GX</td> <td>$\varnothing 0.4$ mm approx. $\varnothing 0.016$ in approx.</td> </tr> </tbody> </table>			Fiber model No.	Distance to focal point	Spot diameter	FD-R33EG FD-EG31	7 ±0.5 mm 0.276 ±0.020 in	$\varnothing 0.1$ mm approx. $\varnothing 0.004$ in approx.	FD-R34EG	$\varnothing 0.15$ mm approx. $\varnothing 0.006$ in approx.	FD-R32EG FD-EG30	$\varnothing 0.2$ mm approx. $\varnothing 0.008$ in approx.	FD-R31G FD-42G/42GW FD-32G/32GX	$\varnothing 0.4$ mm approx. $\varnothing 0.016$ in approx.
		Fiber model No.	Distance to focal point	Spot diameter														
		FD-R33EG FD-EG31	7 ±0.5 mm 0.276 ±0.020 in	$\varnothing 0.1$ mm approx. $\varnothing 0.004$ in approx.														
		FD-R34EG		$\varnothing 0.15$ mm approx. $\varnothing 0.006$ in approx.														
FD-R32EG FD-EG30	$\varnothing 0.2$ mm approx. $\varnothing 0.008$ in approx.																	
FD-R31G FD-42G/42GW FD-32G/32GX	$\varnothing 0.4$ mm approx. $\varnothing 0.016$ in approx.																	
FX-MR6	 <p>Extremely fine spot of $\varnothing 0.1$ mm $\varnothing 0.004$ in approx. achieved.</p> <ul style="list-style-type: none"> Applicable fibers: FD-R33EG, FD-EG31, FD-R34EG, FD-R32EG, FD-EG30, FD-R31G, FD-42G, FD-42GW, FD-32G, FD-32GX Ambient temperature: -20 to +60 °C -4 to $+140$ °F (Note) 	<p>Sensing range for FX-250 series</p> <table border="1"> <thead> <tr> <th>Fiber model No.</th> <th>Distance to focal point</th> <th>Spot diameter</th> </tr> </thead> <tbody> <tr> <td>FD-R33EG FD-EG31</td> <td rowspan="4">7 ±0.5 mm 0.276 ±0.020 in</td> <td>$\varnothing 0.1$ mm approx. $\varnothing 0.004$ in approx.</td> </tr> <tr> <td>FD-R34EG</td> <td>$\varnothing 0.15$ mm approx. $\varnothing 0.006$ in approx.</td> </tr> <tr> <td>FD-R32EG FD-EG30</td> <td>$\varnothing 0.2$ mm approx. $\varnothing 0.008$ in approx.</td> </tr> <tr> <td>FD-R31G FD-42G/42GW FD-32G/32GX</td> <td>$\varnothing 0.4$ mm approx. $\varnothing 0.016$ in approx.</td> </tr> </tbody> </table>			Fiber model No.	Distance to focal point	Spot diameter	FD-R33EG FD-EG31	7 ±0.5 mm 0.276 ±0.020 in	$\varnothing 0.1$ mm approx. $\varnothing 0.004$ in approx.	FD-R34EG	$\varnothing 0.15$ mm approx. $\varnothing 0.006$ in approx.	FD-R32EG FD-EG30	$\varnothing 0.2$ mm approx. $\varnothing 0.008$ in approx.	FD-R31G FD-42G/42GW FD-32G/32GX	$\varnothing 0.4$ mm approx. $\varnothing 0.016$ in approx.		
Fiber model No.	Distance to focal point	Spot diameter																
FD-R33EG FD-EG31	7 ±0.5 mm 0.276 ±0.020 in	$\varnothing 0.1$ mm approx. $\varnothing 0.004$ in approx.																
FD-R34EG		$\varnothing 0.15$ mm approx. $\varnothing 0.006$ in approx.																
FD-R32EG FD-EG30		$\varnothing 0.2$ mm approx. $\varnothing 0.008$ in approx.																
FD-R31G FD-42G/42GW FD-32G/32GX		$\varnothing 0.4$ mm approx. $\varnothing 0.016$ in approx.																
FX-MR3	<p>Extremely fine spot of $\varnothing 0.15$ mm $\varnothing 0.006$ in approx. achieved.</p> <ul style="list-style-type: none"> Applicable fibers: FD-R33EG, FD-EG31, FD-R34EG, FD-R32EG, FD-EG30, FD-R31G, FD-42G, FD-42GW, FD-32G, FD-32GX Ambient temperature: -40 to +70 °C -40 to $+158$ °F (Note) 	<p>Sensing range for FX-250 series</p> <table border="1"> <thead> <tr> <th>Fiber model No.</th> <th>Distance to focal point</th> <th>Spot diameter</th> </tr> </thead> <tbody> <tr> <td>FD-R33EG FD-EG31</td> <td rowspan="4">7.5 ±0.5 mm 0.295 ±0.020 in</td> <td>$\varnothing 0.15$ mm approx. $\varnothing 0.006$ in approx.</td> </tr> <tr> <td>FD-R34EG</td> <td>$\varnothing 0.2$ mm approx. $\varnothing 0.008$ in approx.</td> </tr> <tr> <td>FD-R32EG FD-EG30</td> <td>$\varnothing 0.3$ mm approx. $\varnothing 0.012$ in approx.</td> </tr> <tr> <td>FD-R31G FD-42G/42GW FD-32G/32GX</td> <td>$\varnothing 0.5$ mm approx. $\varnothing 0.020$ in approx.</td> </tr> </tbody> </table>			Fiber model No.	Distance to focal point	Spot diameter	FD-R33EG FD-EG31	7.5 ±0.5 mm 0.295 ±0.020 in	$\varnothing 0.15$ mm approx. $\varnothing 0.006$ in approx.	FD-R34EG	$\varnothing 0.2$ mm approx. $\varnothing 0.008$ in approx.	FD-R32EG FD-EG30	$\varnothing 0.3$ mm approx. $\varnothing 0.012$ in approx.	FD-R31G FD-42G/42GW FD-32G/32GX	$\varnothing 0.5$ mm approx. $\varnothing 0.020$ in approx.		
Fiber model No.	Distance to focal point	Spot diameter																
FD-R33EG FD-EG31	7.5 ±0.5 mm 0.295 ±0.020 in	$\varnothing 0.15$ mm approx. $\varnothing 0.006$ in approx.																
FD-R34EG		$\varnothing 0.2$ mm approx. $\varnothing 0.008$ in approx.																
FD-R32EG FD-EG30		$\varnothing 0.3$ mm approx. $\varnothing 0.012$ in approx.																
FD-R31G FD-42G/42GW FD-32G/32GX		$\varnothing 0.5$ mm approx. $\varnothing 0.020$ in approx.																
Zoom lens	FX-MR8	 <p>The spot diameter is adjustable according to how much the fiber is screwed in.</p> <ul style="list-style-type: none"> Applicable fibers: FD-R33EG, FD-EG31, FD-R34EG, FD-R32EG, FD-EG30, FD-R31G, FD-32G, FD-32GX Ambient temperature: -55 to +70 °C $+67$ to $+158$ °F (Note) 	<p>Sensing range for FX-250 series</p> <table border="1"> <thead> <tr> <th>Fiber model No.</th> <th>Sensing range</th> <th>Spot diameter</th> </tr> </thead> <tbody> <tr> <td>FD-R33EG FD-EG31</td> <td rowspan="4">10 to 30 mm 0.394 to 1.181 in</td> <td>$\varnothing 0.4$ to $\varnothing 2.0$ mm approx. $\varnothing 0.016$ to $\varnothing 0.079$ in approx.</td> </tr> <tr> <td>FD-R34EG</td> <td>$\varnothing 0.4$ to $\varnothing 2.2$ mm approx. $\varnothing 0.016$ to $\varnothing 0.087$ in approx.</td> </tr> <tr> <td>FD-R32EG FD-EG30</td> <td>$\varnothing 0.5$ to $\varnothing 2.5$ mm approx. $\varnothing 0.020$ to $\varnothing 0.098$ in approx.</td> </tr> <tr> <td>FD-R31G FD-32G/32GX</td> <td>$\varnothing 0.8$ to $\varnothing 3.5$ mm approx. $\varnothing 0.031$ to $\varnothing 0.138$ in approx.</td> </tr> </tbody> </table>			Fiber model No.	Sensing range	Spot diameter	FD-R33EG FD-EG31	10 to 30 mm 0.394 to 1.181 in	$\varnothing 0.4$ to $\varnothing 2.0$ mm approx. $\varnothing 0.016$ to $\varnothing 0.079$ in approx.	FD-R34EG	$\varnothing 0.4$ to $\varnothing 2.2$ mm approx. $\varnothing 0.016$ to $\varnothing 0.087$ in approx.	FD-R32EG FD-EG30	$\varnothing 0.5$ to $\varnothing 2.5$ mm approx. $\varnothing 0.020$ to $\varnothing 0.098$ in approx.	FD-R31G FD-32G/32GX	$\varnothing 0.8$ to $\varnothing 3.5$ mm approx. $\varnothing 0.031$ to $\varnothing 0.138$ in approx.	
Fiber model No.	Sensing range	Spot diameter																
FD-R33EG FD-EG31	10 to 30 mm 0.394 to 1.181 in	$\varnothing 0.4$ to $\varnothing 2.0$ mm approx. $\varnothing 0.016$ to $\varnothing 0.079$ in approx.																
FD-R34EG		$\varnothing 0.4$ to $\varnothing 2.2$ mm approx. $\varnothing 0.016$ to $\varnothing 0.087$ in approx.																
FD-R32EG FD-EG30		$\varnothing 0.5$ to $\varnothing 2.5$ mm approx. $\varnothing 0.020$ to $\varnothing 0.098$ in approx.																
FD-R31G FD-32G/32GX		$\varnothing 0.8$ to $\varnothing 3.5$ mm approx. $\varnothing 0.031$ to $\varnothing 0.138$ in approx.																

Note: Refer to LIST OF FIBERS (p.12~) for the ambient temperature of fibers to be used in combination.

FIBER OPTIONS

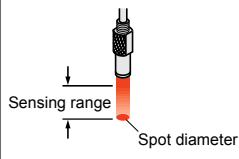
Lens (For reflective type fiber)

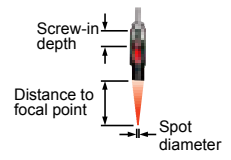
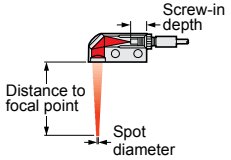
Designation	Model No.	Description														
For reflective type fiber	Parallel light lens	FX-MR9	 <p>Long-range parallel light</p> <ul style="list-style-type: none"> Applicable fibers: FD-R33EG, FD-EG31, FD-R34EG, FD-R32EG, FD-EG30, FD-R31G, FD-42G, FD-42GW, FD-32G, FD-32GX Ambient temperature: -55 to +70 °C +67 to +158 °F (Note) 	Sensing range for FX-250 series <table border="1"> <thead> <tr> <th>Fiber model No.</th> <th>Sensing range</th> <th>Spot diameter</th> </tr> </thead> <tbody> <tr> <td>FD-R33EG FD-EG31</td> <td rowspan="4">0 to 30 mm 0.394 to 1.181 in</td> <td rowspan="4">ø4.0 mm approx. ø0.157 in approx.</td> </tr> <tr> <td>FD-R34EG</td> </tr> <tr> <td>FD-R32EG FD-EG30</td> </tr> <tr> <td>FD-R31G FD-42G/42GW FD-32G/32GX</td> </tr> </tbody> </table>		Fiber model No.	Sensing range	Spot diameter	FD-R33EG FD-EG31	0 to 30 mm 0.394 to 1.181 in	ø4.0 mm approx. ø0.157 in approx.	FD-R34EG	FD-R32EG FD-EG30	FD-R31G FD-42G/42GW FD-32G/32GX		
	Fiber model No.	Sensing range	Spot diameter													
	FD-R33EG FD-EG31	0 to 30 mm 0.394 to 1.181 in	ø4.0 mm approx. ø0.157 in approx.													
	FD-R34EG															
FD-R32EG FD-EG30																
FD-R31G FD-42G/42GW FD-32G/32GX																
Pinpoint spot lens	FX-MR1	 <p>Pinpoint spot of ø0.5 mm ø0.020 in. Enables detection of minute objects or small marks.</p> <ul style="list-style-type: none"> Distance to focal point: 6 ± 1 mm 0.236 ± 0.039 in Applicable fibers: FD-42G, FD-42GW Ambient temperature: -40 to +70 °C -40 to +158 °F (Note) 														
Zoom lens	FX-MR2	 <p>The spot diameter is adjustable from ø0.7 to ø2 mm ø0.028 to ø0.079 in according to how much the fiber is screwed in.</p> <ul style="list-style-type: none"> Applicable fibers: FD-42G, FD-42GW Ambient temperature: -40 to +70 °C -40 to +158 °F (Note) Accessory: MS-EX3 (mounting bracket) 	Sensing range for FX-250 series <table border="1"> <thead> <tr> <th>Screw-in depth</th> <th>Distance to focal point</th> <th>Spot diameter</th> </tr> </thead> <tbody> <tr> <td>7 mm 0.276 in</td> <td>18.5 mm approx. 0.728 in approx.</td> <td>ø0.7 mm approx. ø0.028 in approx.</td> </tr> <tr> <td>12 mm 0.472 in</td> <td>27 mm approx. 1.063 in approx.</td> <td>ø1.2 mm approx. ø0.047 in approx.</td> </tr> <tr> <td>14 mm 0.551 in</td> <td>43 mm approx. 1.693 in approx.</td> <td>ø2.0 mm approx. ø0.079 in approx.</td> </tr> </tbody> </table>		Screw-in depth	Distance to focal point	Spot diameter	7 mm 0.276 in	18.5 mm approx. 0.728 in approx.	ø0.7 mm approx. ø0.028 in approx.	12 mm 0.472 in	27 mm approx. 1.063 in approx.	ø1.2 mm approx. ø0.047 in approx.	14 mm 0.551 in	43 mm approx. 1.693 in approx.	ø2.0 mm approx. ø0.079 in approx.
Screw-in depth	Distance to focal point	Spot diameter														
7 mm 0.276 in	18.5 mm approx. 0.728 in approx.	ø0.7 mm approx. ø0.028 in approx.														
12 mm 0.472 in	27 mm approx. 1.063 in approx.	ø1.2 mm approx. ø0.047 in approx.														
14 mm 0.551 in	43 mm approx. 1.693 in approx.	ø2.0 mm approx. ø0.079 in approx.														
Zoom lens (side-view type)	FX-MR5	 <p>FX-MR2 is converted into a side-view type and can be mounted in a very small space.</p> <ul style="list-style-type: none"> Applicable fibers: FD-42G, FD-42GW Ambient temperature: -40 to +60 °C -40 to +140 °F (Note) 	Sensing range for FX-250 series <table border="1"> <thead> <tr> <th>Screw-in depth</th> <th>Distance to focal point</th> <th>Spot diameter</th> </tr> </thead> <tbody> <tr> <td>8 mm 0.315 in</td> <td>13 mm approx. 0.512 in approx.</td> <td>ø0.5 mm approx. ø0.020 in approx.</td> </tr> <tr> <td>10 mm 0.394 in</td> <td>15 mm approx. 0.591 in approx.</td> <td>ø0.8 mm approx. ø0.031 in approx.</td> </tr> <tr> <td>14 mm 0.551 in</td> <td>30 mm approx. 1.181 in approx.</td> <td>ø3.0 mm approx. ø0.118 in approx.</td> </tr> </tbody> </table>		Screw-in depth	Distance to focal point	Spot diameter	8 mm 0.315 in	13 mm approx. 0.512 in approx.	ø0.5 mm approx. ø0.020 in approx.	10 mm 0.394 in	15 mm approx. 0.591 in approx.	ø0.8 mm approx. ø0.031 in approx.	14 mm 0.551 in	30 mm approx. 1.181 in approx.	ø3.0 mm approx. ø0.118 in approx.
Screw-in depth	Distance to focal point	Spot diameter														
8 mm 0.315 in	13 mm approx. 0.512 in approx.	ø0.5 mm approx. ø0.020 in approx.														
10 mm 0.394 in	15 mm approx. 0.591 in approx.	ø0.8 mm approx. ø0.031 in approx.														
14 mm 0.551 in	30 mm approx. 1.181 in approx.	ø3.0 mm approx. ø0.118 in approx.														

Note: Refer to [LIST OF FIBERS](#) (p.12~) for the ambient temperature of fibers to be used in combination.

FIBER OPTIONS

Others

Designation	Model No.	Description			
Protective tube for thru-beam type fiber	FTP-500 (0.5 m 1.640 ft)	For M4 thread	FT-42 FT-42S FT-42W	FT-43 FT-H13-FM2	
	FTP-1000 (1 m 3.281 ft)		Applicable fibers	FT-31 FT-31S FT-31W	FD-31 FD-31W
	FTP-1500 (1.5 m 4.921 ft)			For M3 thread	FD-61 FD-61S FD-61W
	FTP-N500 (0.5 m 1.640 ft)	For M6 thread			FD-41 FD-41W
	FTP-N1000 (1 m 3.281 ft)				
	FTP-N1500 (1.5 m 4.921 ft)				
Protective tube for reflective type fiber	FDP-500 (0.5 m 1.640 ft)	For M6 thread	FD-61 FD-61S FD-61W	FD-62 FD-H13-FM2	
	FDP-1000 (1 m 3.281 ft)				
	FDP-1500 (1.5 m 4.921 ft)	For M4 thread	FD-41 FD-41W	FD-41S FD-41SW	
	FDP-N500 (0.5 m 1.640 ft)				
	FDP-N1000 (1 m 3.281 ft)				
	FDP-N1500 (1.5 m 4.921 ft)				
Universal sensor mounting stand	MS-AJ1-F	Horizontal mounting type	Mounting stand assembly for fiber (For M3, M4 or M6 threaded head fiber)		
	MS-AJ2-F	Vertical mounting type			
Liquid inflow prevention joint (Note)	MS-FX-01Y	Applicable fibers	FD-HF40Y	This joint suppresses false operations due to liquid slip-in from the top of the protective tube.	
Protective tube extension joint (Note)	MS-FX-02Y			The protective tube can be extended.	
Fiber mounting joint (Note)	MS-FX-03Y			The joint is used for mounting fibers on a tank.	
Single core holder	FX-AT15A	The incident light intensity may vary when using a multi-core fiber or a thin type sharp bending fiber. This holder suppresses the variation in the incident light intensity. (Brown)			
Reflector	RF-210	Used with FR-Z50HW . Refer to p.38 for the sensing range of FR-Z50HW to be used in combination.			
	RF-220				
	RF-230				

Note: The joint internal ferrule (MS-FX-YF) is available as a spare part. A distorted ferrule may result in leakage.

Protective tube

- FTP-□
- FDP-□



Universal sensor mounting stand

Using the arm which enables adjustment in the horizontal direction, sensing can also be done from above an assembly line.

- MS-AJ1-F

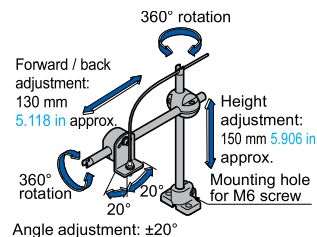

- MS-AJ2-F

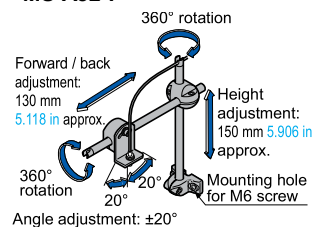

Single core holder

- FX-AT15A



Liquid inflow prevention joint

- MS-FX-01Y

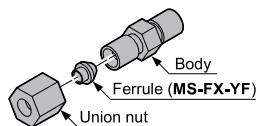

Protective tube extension joint

- MS-FX-02Y

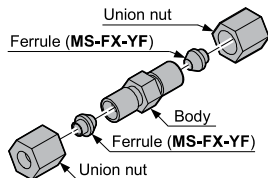

Fiber mounting joint

- MS-FX-03Y

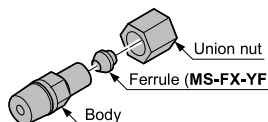

Reflector

- RF-210

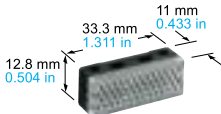

- RF-220

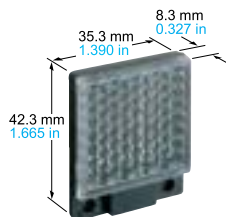

- RF-230

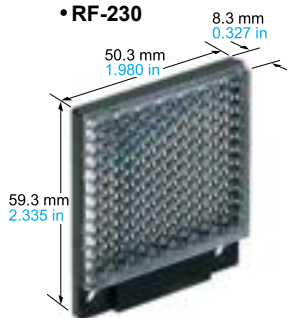

FIBER OPTIONS

Model No. when ordering heat-resistant fibers individually as spare parts

- Heat-resistant side fiber
FT-H20-J20 (one pair set)
FT-H20-J30 (one pair set)
FT-H20-J50 (one pair set)
FT-H20-VJ50 (one pair set)
FT-H20-VJ80 (one pair set)
- Ordinary temperature side fiber
FT-42 (one pair set)

Model No. when ordering vacuum-resistant fibers individually as spare parts

- Vacuum-resistant fiber
FT-H30-M1V (one pair set)
FD-H30-KZ1V
FD-H30-L32V
- Photo-terminal
FV-BR1 (one pair set)
- Fiber at atmospheric side
FT-J8 (one pair set)
- Mounting bracket for **FD-KZ50V / FD-H30-KZ1V(-S)**
MS-FD-2

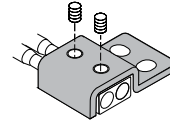

Model No. when ordering accessories additionally

- **RF-003** (Reflector for **FR-KZ50E/KZ50H**)
- **RF-13** (Reflective tape for **FR-Z50HW**)
- **FX-CT2** (Fiber cutter)
- **FX-CT3** (Fiber cutter for $\varnothing 1\text{mm } \varnothing 0.039\text{ in}$ / $\varnothing 1.3\text{mm } \varnothing 0.051\text{ in}$ fiber cable / $\varnothing 4\text{mm } \varnothing 0.157\text{ in}$ protective tube)
- **FX-CT4** (Fiber cutter for $\varnothing 2\text{mm } \varnothing 0.079\text{ in}$ fiber cable / $\varnothing 4\text{mm } \varnothing 0.157\text{ in}$ protective tube)
- **FX-AT2** (Attachment for fixed-length fiber, Orange)
- **FX-AT3** (Attachment for $\varnothing 2.2\text{ mm } \varnothing 0.087\text{ in}$ fiber, Clear orange)
- **FX-AT4** (Attachment for $\varnothing 1\text{ mm } \varnothing 0.039\text{ in}$ fiber, Black)
- **FX-AT5** (Attachment for $\varnothing 1.3\text{ mm } \varnothing 0.051\text{ in}$ fiber, Gray)
- **FX-AT6** (Attachment for $\varnothing 1\text{ mm } \varnothing 0.039\text{ in}$ / $\varnothing 1.3\text{ mm } \varnothing 0.051\text{ in}$ mixed fiber, Black / Gray)
- **FX-AT4G1** (Gland single for $\varnothing 1\text{ mm } \varnothing 0.039\text{ in}$ fiber, Black)
- **FX-AT5G1** (Gland single for $\varnothing 1.3\text{ mm } \varnothing 0.051\text{ in}$ fiber, Gray)
- **FX-AT6G1** (Gland single for $\varnothing 1\text{ mm } \varnothing 0.039\text{ in}$ / $\varnothing 1.3\text{ mm } \varnothing 0.051\text{ in}$ mixed fiber, Black / Gray)
- **FX-SL1** (Slit mask for **FT-A11 / FT-A11W** (one pair set), slit size: $0.5 \times 12\text{ mm } 0.020 \times 0.472\text{ in}$)
- **FX-SL2** (Slit mask for **FT-A11 / FT-A11W** (one pair set), slit size: $1 \times 12\text{ mm } 0.039 \times 0.472\text{ in}$)
- **FX-SL3** (Slit mask for **FT-A32 / FT-A32W** (one pair set), slit size: $0.5 \times 33\text{ mm } 0.020 \times 1.299\text{ in}$)
- **MS-FD-2** (Fiber mounting bracket)
- **MS-FD-F7-1** (SUS mounting bracket for **FD-F71**)
- **MS-FD-F7-2** (PVC mounting bracket for **FD-F71**)

• RF-003



• RF-13



• FX-CT2



• FX-CT3



• FX-CT4



• FX-AT2

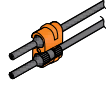

• FX-AT3

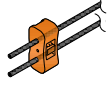

• FX-AT4

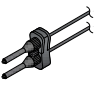

• FX-AT5

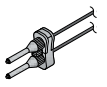

• FX-AT6

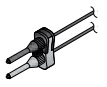

• FX-AT4G1



• FX-AT5G1



• FX-AT6G1



• FX-SL1

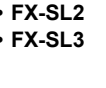

• FX-SL2



• FX-SL3

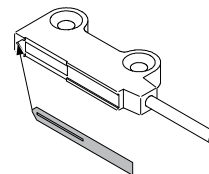

• MS-FD-2

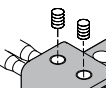

• MS-FD-F7-1

(SUS mounting bracket for **FD-F71**)

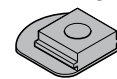

• MS-FD-F7-2

(PVC mounting bracket for **FD-F71**)

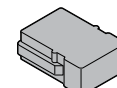

Disclaimer

The applications described in the catalog are all intended for examples only. The purchase of our products described in the catalog shall not be regarded as granting of a license to use our products in the described applications. We do NOT warrant that we have obtained some intellectual properties, such as patent rights, with respect to such applications, or that the described applications may not infringe any intellectual property rights, such as patent rights, of a third party.